



الهيئة العامة للزكاة والدخل
General Authority of Zakat & Tax

Transfer Pricing Guidelines

Version 1
March 2019

www.gazt.gov.sa

Disclaimer:

The General Authority of Zakat and Tax warns against the use of and reliance upon regulations, bylaws, and Guidelines other than final approved versions published on the Authority's website www.gazt.gov.sa; the Authority shall not be liable for any loss or damage arising out of the use of unofficial or unapproved documents.

Table of Contents

Definitions	5
Acronyms & Abbreviations	19
1. Introduction	21
1.1. Summary	22
1.2. Application of transfer pricing rules to the tax system in the Kingdom of Saudi Arabia	22
1.3. General Authority of Zakat and Tax	23
1.4. This Guideline	23
2. What is Transfer Pricing	25
2.1. Basic Premise	26
2.2. Transfer pricing framework	27
2.3. Arm's Length Principle	29
3. Subjects	31
3.1. Persons	33
3.2. Related Persons	34
4. Comparability analysis: identification and determination	43
4.1. Step 1: Identification of the Controlled Transaction	45
4.2. Step 2: Selection of TP Method	54
4.3. Step 3: Selection of comparables	77
4.4. Financial analysis	82
5. Transfer Pricing Documentation	85
5.1. Basic premise	87
5.2. General documentation	89
5.3. Master File and Local File	90
5.4. Country-by-Country reporting	92
5.5. Country-by-Country notification	101
5.6. Disclosure Form	101
6. Implementation	106
6.1. General aspects	107

7. Specific Guidance: Financial Transactions	109
7.1. Loan transactions	110
7.2. Guarantees	112
7.3. Cash management, optimization and cash pooling	113
7.4. Factoring	114
7.5. Securitization	115
7.6. Hedging	116
7.7. Captive insurance	117
8. Specific Guidance: Intangibles	119
8.1. What is an Intangible?	121
8.2. Applying the Arm's Length Principle with respect to Intangibles	122
8.3. The purchase of shares in an Independent Person followed by a business restructuring	128
9. Specific Guidance: Business Restructuring	130
9.1. What may constitute a Business Restructuring?	131
9.2. Understanding the Business Restructuring	132
9.3. Relocation of profit potential as a result of a Business Restructuring	135
9.4. Indemnification of the restructured Person	136
10. Valuation	138
10.1. Use of valuation techniques	139
10.2. Price adjustment clause	141
11. Permanent Establishments	142
11.1. Application of the Arm's Length Principle to a Permanent Establishment	143
12. Audit and risk assessments	145
12.1. Burden of Proof	146
12.2. Transfer Pricing Adjustments	147
13. Appendix	148

Definitions

Definition	Meaning
"Approved Transfer Pricing Methods"	means the methods enumerated in Article 7 of the Bylaws or used pursuant to Article 9 of the Bylaws.
"Arm's Length Pricing"	means the pricing of a service/goods/capital loan or Intangibles which two or more Independent Persons determine according to market forces and Uncontrolled Transaction conditions.
"Arm's Length Principle or Arm's Length"	where conditions are made or imposed between two or more Related Persons in their commercial or financial relations which differ from those which would be made between Independent Persons, then any profits which would, but for those conditions, have accrued to one of such Related Persons, but by reason of those conditions, have not so accrued, may be included in the profits of that person and taxed accordingly.
"Arm's Length Range"	means a range of acceptable Arm's Length financial indicator figures (such as (without limitation) prices, margins, or profit shares) produced by the application of the most appropriate Transfer Pricing method selected in accordance the Bylaws to a number of Uncontrolled Transactions, each of which is relatively equally comparable to the Controlled Transaction based on a comparability analysis conducted in accordance with the Bylaws.
the "Authority"	means the General Authority of Zakat and Tax.
"Business Restructuring"	means a cross-border or domestic reorganization of the commercial or financial relations between Related Persons, including the termination or substantial renegotiation of existing arrangements.
"Bylaws" or "TP Bylaws"	Transfer Pricing Bylaws pursuant to Ministerial Resolution No. [6-1-19] dated 25/05/1440 H. corresponding to 31/01/2019.

Definition	Meaning
"Cost Plus method" or "C+"	Cost Plus Method means one of the Approved TP Method that measures the costs incurred by the supplier of property (or services) in a Controlled Transaction for property transferred or services provided to a related purchaser. An appropriate cost plus markup (being a gross margin) is then added to this cost, to make an appropriate profit in light of the functions performed and the market conditions.
"Country-by-Country Reporting" or "CbCR"	Country-by-Country Report required as per Article 18 of the Bylaws and refers to the report required to be submitted by MNE Groups on its operations in each country.
"CbCR Notification"	means the notification for CbCR purposes set forth in article 18(F) of the Bylaws.
"Chartered Accountant Certificate"	means the affidavit required pursuant to Article 14 (C) of the Bylaws from the Taxpayer's licensed auditor in the Kingdom through which the auditor certifies that the Transfer Pricing policy of the MNE Group is consistently applied by and in relation to the Taxpayer.
"Comparable Transaction"	means an Uncontrolled Transaction which is comparable to a Controlled Transaction when: (a) There are no significant differences between them that could materially affect the financial indicator being examined under the appropriate Transfer Pricing Method; or (b) When such material differences exist, if a reasonably accurate comparability adjustment is made to the relevant financial indicator of the Uncontrolled Transaction in order to eliminate the effects of such differences on the comparison.

Definition	Meaning
"Constituent Entity of an MNE Group"	<p>means</p> <p>(a) any separate business unit of a multinational enterprise group, that is included in the consolidated financial statements of the MNE Group for financial reporting purposes, or would be so included if equity interests in such business unit of an MNE Group were traded on a public securities exchange;</p> <p>(b) any such business unit that is excluded from the MNE Group's consolidated financial statements solely on materiality grounds; and</p> <p>(c) any Permanent Establishment of any separate business unit of the MNE Group included in subparagraphs (a) or (b) above provided the business unit prepares or should prepare a separate financial statement of such Permanent Establishment for financial reporting, regulatory reporting, tax reporting, or internal management control purposes.</p>
"Consolidated Financial Statements"	<p>means the financial statements of an MNE Group in which the assets, liabilities, income, expenses and cash flows of the Ultimate Parent Entity and the Constituent Entities are presented as those of a single economic entity.</p>
"Controlled Transaction"	<p>means any Transaction involving Related Persons. Controlled Transactions shall include any national Transactions or consideration exchanged between a Person and its Permanent establishment, to the extent that such Transactions are recognized for the purpose of the Income Tax Law.</p>
"Corresponding Adjustment"	<p>means Corresponding Adjustment set forth in Article 20 of the Bylaws.</p>
"Comparable Uncontrolled Price Method" or "CUP"	<p>refers to the Approved TP Method that compares the price charged for property or services transferred in Controlled Transactions to the price that is charged in comparable Transactions under comparable circumstances.</p>

Definition	Meaning
"Dealings"	means the 'deemed' Transactions between the Person and the Permanent Establishment of that Person. This is comparable to the Controlled Transactions between two Related Persons.
"Disclosure Form"	means the document or set of documents that the Taxpayer must submit to the Authority pursuant to Article 14 of the Bylaws.

Definition	Meaning
"Effective Control"	<p>means the ability of a Person to control the business decisions of another Person. For purposes of the Bylaws, a Person or group of Persons, either jointly or severally, directly or indirectly, are presumed to be able to control the business decisions of another Person in any of the following cases - without limitations:</p> <p>(a) such Person or Persons have the ability to conclude an agreement to provide management services to the company or otherwise effectively perform the functions of management for the other Person;</p> <p>(b) such Person or Persons have the ability to act as trustee (manager) of the other Person or Persons under a trust arrangement;</p> <p>(c) such Person or Persons have the ability to directly or indirectly control the composition of 50% or more of the board of directors or has/have the right to appoint or dismiss the representatives of management of the other Person or Persons;</p> <p>(d) such Person or Persons have a legal or de facto right to receive, directly or indirectly, 50% or more of the profits of the other Person or Persons;</p> <p>(e) such Person or Persons, except where such Person is a Financial Institution, have provided loans to the Person or Persons directly or indirectly and the total outstanding balance of such loans represents 50% or more of the of long term & short term debt and capital excluding retained earnings as of the year-end balance of the Reporting Year;</p> <p>(f) such Person or Persons, with the exception of Financial Institutions, have issued guarantees to cover 25% or more of the value of the Person's total borrowings as of the year-end balance of the Reporting Year;</p>

Definition	Meaning
	<p>(g) 50% or more of the absolute aggregated value of a Person's business activities as of the year-end balance of the Reporting Year depends on Transactions with such other Person or Persons;</p> <p>(h) such Person or Persons are Related Person to a Person who directly or indirectly holds 50% or more of a juridical person or they participate, directly or indirectly, in the management of the juridical person;</p> <p>(i) a Person is or Related Persons, jointly or severally, are the principal or supplier of a Person under an exclusive agency, distributorship arrangement or any such similar contract for the sale of goods, services or rights and such Person is a dependent agent of the principal and who is prohibited from entering into other similar agency, distributorship arrangement or any such similar arrangement for the duration of the Person's relationship with the principal;</p> <p>(j) in the case of a nonresident Person or Related Persons, where a substantial portion of the business activities of a Resident Person depends on Transactions with the nonresident Person or Related Persons, and the Resident Person's business activities depend on rights in Intangible property granted to such Person on an exclusive basis directly or indirectly by the nonresident Person or Related Persons; or</p> <p>(k) the Person or Related Persons, jointly or severally, are able to control the business decisions of the other Person in any other way as evidenced by the facts and circumstances.</p>
"Functional Analysis"	the analysis or study aimed at identifying the economically significant activities and responsibilities undertaken, assets used or contributed, and risks assumed by the parties to the Transaction.
The "Guidelines"	the Transfer Pricing Guidelines published by GAZT to provide background and guidance on the transfer pricing requirements for Taxable Persons.

Definition	Meaning
"Identifying Name"	means a name other than the legal name of a Person that could identify a Person. This includes names used in the ordinary course of business or used in conducting business activities such as tradenames.
"Independent Persons"	means Persons who are not Related Persons or Persons under Common Control.
"Intangible Asset" or "Intangible"	means property that is not tangible or physical and that is not a physical asset or a financial asset that is capable of being owned or controlled for use in commercial activities and the use or transfer of which would be compensated had it occurred in an Uncontrolled Transaction in comparable circumstances.
"International Agreement"	the Multilateral Convention for Mutual Administrative Assistance in Tax Matters, any bilateral or multilateral tax convention, or any tax information exchange agreement to which the Kingdom is a party and pursuant to which jurisdictions commit to the mutual exchange of tax information, including automatic exchange of such information.
The "Law" or the "Income Tax Law"	the Income Tax Law (issued by Royal Decree No. (M/1) dated 15/1/1425H and the amendments thereto.
"Local File"	means the Local File containing detailed information on all Controlled Transactions of the Taxable Person and other information in accordance with Article 17 of the Bylaws.
"Master File"	means the Master File containing information on the global business operations and Transfer Pricing policies of the Multinational Enterprise Group to which the Taxable Person belongs and containing the information required in accordance with Article 16 of the Bylaws.
"Mixed Companies"	means companies owned by both a Person covered by Article 2 of the Zakat Regulations (Ministerial Resolution No. 2082 dated 1/6/1438 H) as well as a Person subject to the Income Tax Law.

Definition	Meaning
"MNE" or "MNE Group" or "Group"	Multinational Enterprise Group, means: (a) a group of two or more Persons, the tax residencies of whom are in different jurisdictions; or (2) any group that includes a Person that, for tax purposes, is a resident in one jurisdiction and is also subject to tax in another jurisdiction as a result of having a Permanent Establishment in the other jurisdiction.
"Net Cost Plus Method" or "NCP"	Net Cost-Plus, and means a measure of return on costs using the total operational cost of the Person (excluding interest payments and tax expense).
"OECD TP Guidelines"	The OECD Transfer Pricing Guidelines for Multinational Enterprises and Tax Administrations.
"Operating Profit Margin" or "OPM"	means the margin calculated by dividing earnings before interest and tax (EBIT) or operating profit by net sales.
"Person"	means a natural or juridical person; where a juridical person is any non-natural person recognized by law or fact to have legal personality, including Permanent Establishments.
"Place of Effective Management"	means the place where key management and commercial decisions that are necessary for the conduct of the entity's business are in substance made. The place of effective management will ordinarily be the place where the most senior person or group of persons (for example a board of directors) makes its decisions, the place where the actions to be taken by the entity as a whole are determined; however, no definitive rule can be given and all relevant facts and circumstances must be examined to determine the place of effective management. An entity may have more than one place of management, but it can have only one place of effective management at any one time.

Definition	Meaning
"Profit Level Indicator" or "PLI"	means the denominator of the net margin indicator that should reflect the relevant indicators of value of the functions performed by the Tested Party in the Transaction under review, taking into account its risks assumed and asset employed.
"Profit Split Method" or "PSM"	means an approved TP Method that identifies the combined profit for the Related Persons from a Controlled Transaction or Transactions. Thereafter, the PSM splits those profits between the Related Persons on an economically valid basis.
"Qualifying Competent Authority Agreement"	means an agreement that is between authorized representatives of the jurisdictions that are parties to an International Agreement pursuant to which the jurisdictions are required to automatically exchange CbC Reports.

Definition	Meaning
"Related Persons"	<p>means</p> <p>(a) two or more natural persons if they are:</p> <p>(i) relatives through marriage or are otherwise relatives to the fourth degree; or</p> <p>(ii) partners in a partnership</p> <p>(b) a natural person is considered related to a juridical person in any of the following circumstances:</p> <p>(i) if the natural person is a partner in a Partnership and he, either alone or together with a Related Person or Persons, directly, indirectly (or both) controls 50% or more of the voting rights, income, capital of the Partnership.</p> <p>(ii) if the Person or a Related Person thereto is a shareholder in a Capital Company and he, either alone or together with a Related Person or Persons, directly, indirectly (or both) controls 50% or more of the voting rights, income or capital of the Capital Company.</p> <p>(iii) as for agencies administering property held in a trust, fund or any such similar arrangement, a natural person is considered related thereto if he benefits or is capable of benefiting from them, either alone or with a related Person or Persons.</p> <p>(iv) if the Person alone or jointly with a Related Person thereto directly or indirectly participates or is able to participate in the management, control or capital of a juridical person.</p> <p>(c) two or more juridical persons are considered Related Persons in any of the following cases:</p> <p>(i) they are Persons under Common Control.</p> <p>(ii) when the Person who controls or has the ability to control the business decisions of a juridical person has, alone or together with a Related Person, Effective Control over the other juridical person.</p> <p>(iii) when the Person who has Effective Control over a juridical person and the Person who has Effective Control of the other juridical person are Related Persons.</p>

Definition	Meaning
"Regulated Financial Institutions"	means for an institution licensed to provide services in the Kingdom, a juridical person subject to regulation by the Saudi Arabian Monetary Authority or any other government agency in accordance with the laws and regulations in the Kingdom. As for institutions not authorized to provide services in the Kingdom and not subject to the regulatory jurisdiction of the Kingdom, the term means a juridical Person considered a bank or a financing company in the jurisdiction in which such Person carries out activities and whose activities and purpose are substantially similar to those of institutions that would be considered a bank or financing company under the laws and regulations of the Kingdom, and provided that such Person is licensed in that other jurisdiction to conduct such banking or financing activities (as the case may be) and is regulated by an agency of the central government of such jurisdiction such as the treasury or central bank in a manner similar to the way it would have been regulated in the Kingdom had it been subject to the regulatory jurisdiction of the Kingdom.
"Regulated Financial Services"	means the financial services provided by Regulated Financial Institutions.
"Reporting Entity"	means a Constituent Entity that is required to submit a Country-by-Country Report to The Authority or any other tax authority on behalf of a Multinational Enterprise Group.
"Reporting Year"	means the reporting year as defined in the Law of the Kingdom of Saudi Arabia.
"Return on (operating) Assets" or "RoA"	means operating profit divided by operating assets.
"Return of Capital Employed" or "RoCE"	means operating profit divided by operating assets.

Definition	Meaning
"Return On Sales" or "ROS"	means the margin calculated by dividing earnings before interest and tax ("EBIT") or operating profit by net sales.
"Resale Price Method" or "RPM"	means one of the Approved TP Methods that evaluates whether the amount charged in a Controlled Transaction is at Arm's Length by taking into consideration the gross margin that is realized in comparable Uncontrolled Transactions.
"Separate Entity Approach" or "SEA"	means where, for purposes of implementing the Arm's Length Principle, members of the MNE Group (including PEs) are treated as separate entities that are operate on an independent basis rather than being inseparable from the MNE Group to which they belong.
"Small Enterprise"	a juridical person who carries out Controlled Transactions, for which the total arm's length value does not exceed six-million Saudi Riyals (SAR 6,000,000) in a 12 month period.
"Statutory Consolidated Revenue"	means an MNE Group's consolidated group revenue exceeding Three Billion & Two Hundred Million Saudi Riyals (SAR 3.2 Billion) during the year immediately preceding the current Reporting Year as reflected in the Group's Consolidated Financial Statements for that preceding year.
"Surrogate Parent Entity" or "SPE"	means one Constituent Entity of the MNE Group that has been appointed by such MNE Group, as a sole substitute for the Ultimate Parent Entity, to file the Country-by-Country- Report in that Constituent Entity's Tax Jurisdiction, on behalf of such MNE Group, when one or more of the conditions set out in Article 18 of the Bylaws applies.

Definition	Meaning
"Systemic Failure"	means the persistent failure of a jurisdiction that is a party to an enforceable Qualifying Competent Authority Agreement to which the Kingdom is a party, to automatically provide the Kingdom with CbC Reports available or could be made available to it in respect of MNE Groups that have Constituent Entities in the Kingdom, or jurisdictions in which automatic exchange is effectively suspended for reasons that are not in accordance with the terms of that Qualifying Competent Authority Agreement.
"Tangible Asset"	assets including man-made (produced) non-financial assets and non-produced natural assets and excluding intangible (non-produced) assets such as patents or goodwill.
"Tax Jurisdiction"	means the jurisdiction in which a Person is considered a Person subject to tax or a taxpayer pursuant to the laws of that jurisdiction.
"Taxable Person" or "Taxpayer"	means a Person subject to tax per the law of KSA. For the purposes of the Guideline and Bylaws, whenever a Person who is not a Person subject to tax is required to comply with the Bylaws or any part thereof, the term Taxable Person is deemed to include such person.
"Terms Economically Relevant" or "Economically Relevant Terms"	means the characteristics, elements, factors, or any other aspect of a Transaction that Independent Parties would take into account when evaluating the Transaction.
"Tested Party"	means the least complex party of the Related Persons in a Controlled Transaction.
"Transactional Net Margin Method" or "TNMM"	means the Approved TP Method that compares the net profit level between the Controlled Transactions and Uncontrolled Transactions.

Definition	Meaning
"Transaction"	means any arrangement, understanding, agreement, or mutual practice whether or not legally enforceable or intended to be legally enforceable, undertaken between two or more Persons.
"Transfer Pricing" or "TP"	means setting of prices for Controlled Transactions, including but not limited to the provision of goods, services, loans and Intangibles.
"Transfer Pricing Method"	means any of the transfer pricing methods set forth in Article 7 of the Bylaws.
"Transfer Pricing Policy"	means the approach taken by Related Parties when determining the price for the product or service.
"Ultimate Parent Entity" or "UPE"	means a Constituent Entity of an MNE Group that: (a) owns directly or indirectly a sufficient interest in one or more other Constituent Entities of such MNE Group such that it is required to prepare consolidated financial statements under accounting principles generally applied in its country of tax residence, or would be so required if its equity interests were traded on public securities exchange in its country of tax residence; and (b) there is no other Constituent Entity of such MNE Group that owns directly or indirectly an interest described in paragraph (a) above.
"Uncontrolled Transactions"	means a Transaction other than a Controlled Transaction.

All other terms not defined herein have the same meaning as defined in the Law and/or Implementing Regulations.

Acronyms & Abbreviations

Acronyms	Definition
"AOA"	Authorized OECD Approach
"C+"	Cost Plus
"CbCR"	Country-by-Country Report
"CE"	Constituent Entity
"CUP"	Comparable Uncontrolled Price Method
"DEMPE"	Development, Enhancement, Maintenance, Protection and Exploitation
"EBIT"	Earnings before Interest and Taxation
"FCM"	Full-Cost Markup
"GAZT"	General Authority of Zakat and Tax
"KSA"	the Kingdom of Saudi Arabia
"MNE"	Multinational Enterprise
"NCP"	Net Cost Plus
"OECD"	Organization for Economic Cooperation & Development
"OPM"	Operating Profit Margin
"PE"	Permanent Establishment
"PLI"	Profit Level Indicator
"PSM"	Profit Split Method
"RoA"	Return on Assets
"RoCE"	Return on Capital Employed
"RoS"	Return on Sales
"RPM"	Retail Price Method

Acronyms	Definition
"SAR"	Saudi Riyal
"SCRT"	Statutory Consolidated Revenue Threshold
"SEA"	Separate Entity Approach
"SPE"	Surrogate Parent Entity
"TNMM"	Transactional Net Margin Method
"TP"	Transfer Pricing
"TIN"	Tax Identification Number
"UPE"	Ultimate Parent Entity

1. Introduction

1. Introduction

1.1. Summary

- Pursuant to Board Resolution No. [6-1-19] 25/5/1440H (31/12/2018 G), the the General Authority of Zakat and Tax “GAZT” has issued the Kingdom’s Transfer Pricing Bylaws (“TP Bylaws”) which apply to all Taxable Persons in the Kingdom (“KSA”). For Persons covered by Article 2 of the Zakat Regulations (Ministerial Resolution No. 2082 dated 1/6/1438 H) the TP Bylaws shall only be applicable insofar they are meeting the obligations of Article 18 of the Bylaws. These Bylaws set out a framework to set prices for Controlled Transactions, including but not limited to transfers of goods, services, loans and Intangibles (intellectual property).
- This Guideline serves to provide insight and guidance in the Transfer Pricing practice of the KSA and represents the Authority’s views on the application of the TP Bylaws.

1.2. Application of transfer pricing rules to the tax system in the Kingdom of Saudi Arabia

The provisions of the Income Tax Law (issued by Royal Decree No. (M/1) dated 15/1/1425H and the amendments thereon) to apply to resident capital companies, with respect to shares of non-Saudi partners. Further, the provisions of Income Tax Law also apply to:

- A resident non-Saudi natural person who conducts business in the KSA.
- A nonresident who conducts business in the KSA through a permanent establishment (“PE”).
- A nonresident with other taxable income from sources within the KSA.
- A Person engaged in the field of natural gas investment.
- A Person engaged in the field of oil and hydrocarbons production.

For further details on the subjects to this Guideline please see Chapter 3.

For Persons subject to Zakat pursuant to article 2 of the Zakat Regulations issued by (Ministerial Resolution No. 2082 dated 1/6/1438 H) the TP Bylaws may -in certain situations- only be applicable to such Persons insofar they are required to satisfy the CbCR obligations under Article 18 of the Bylaws. The Bylaws set out a framework to set prices for Controlled Transactions, including but not limited to transfers of goods, services, loans and Intangibles. The concept of Transfer Pricing is not new to the income tax practice of the Kingdom. However, the Bylaws introduced detailed provisions with respect to Transfer Pricing.

1.3. General Authority of Zakat and Tax

The Authority is the government body tasked with regulating, enforcing, administering and implementing taxation in the KSA, including the TP Bylaws.

1.4. This Guideline

This Transfer Pricing Guideline (“Guideline”) published by the Authority provides guidance and background on the Transfer Pricing requirements for Taxable Persons.

This Guideline serves to provide insights and guidance on the Transfer Pricing practice of the KSA; it provides insight into the Authority’s interpretation and understanding on the TP Bylaws. This Guideline solely serve as Guidance material, and does not include or purport to include information about all provisions of the Bylaws nor all TP issues. While the Guideline is not a binding document, it nonetheless provides information about GAZT’s possible approach to certain TP issues on a practical level.

For this Guideline, the latest version of the OECD Transfer Pricing Guidelines for Multinational Enterprises and Tax Administrations (“OECD TP Guidelines”) is used as a source of information in respect of the overarching Transfer Pricing Principles. Although the OECD TP Guideline contains valuable information, material and documents issued by GAZT shall supersede any other source with respect to Transfer Pricing. Taxpayers are encouraged to refer to OECD TP Guidelines if an issue is not addressed herein. However, Taxpayers who make any

act or omission pursuant to the OECD Guidelines or any other source that is contrary to the laws and regulations of the Kingdom or GAZT's policies will do so at their own risk.

The goal of publishing this Guideline is to minimize any ambiguities for Taxpayers in the KSA on the implementation and application of the local Transfer Pricing legislation. In principle, cooperation between Taxpayers and the Authority is intended where both parties have a clear understanding and respect for the position and interests of the other party.

The intention for the Authority to cooperate with Taxpayers does not eliminate the possibility of disagreements between Taxpayers and the Authority. Nor does it impact on the ability of the Authority to conduct audits or impose fines if the Authority is of the view that a Taxpayer is non-compliant with the TP Bylaws.

In case a Taxpayer requires more information about the application of the TP Bylaws or Guideline to its own situation, the Taxpayer can approach GAZT for a non-binding request for clarification. GAZT will endeavor to provide the Taxpayer with information on the application of TP provisions for that specific situation.

Note that this document solely serves as a translation of the Arabic version. In case of any discrepancies between this version and the Arabic version, the information included in the Arabic version supersedes.

2.

What is Transfer Pricing

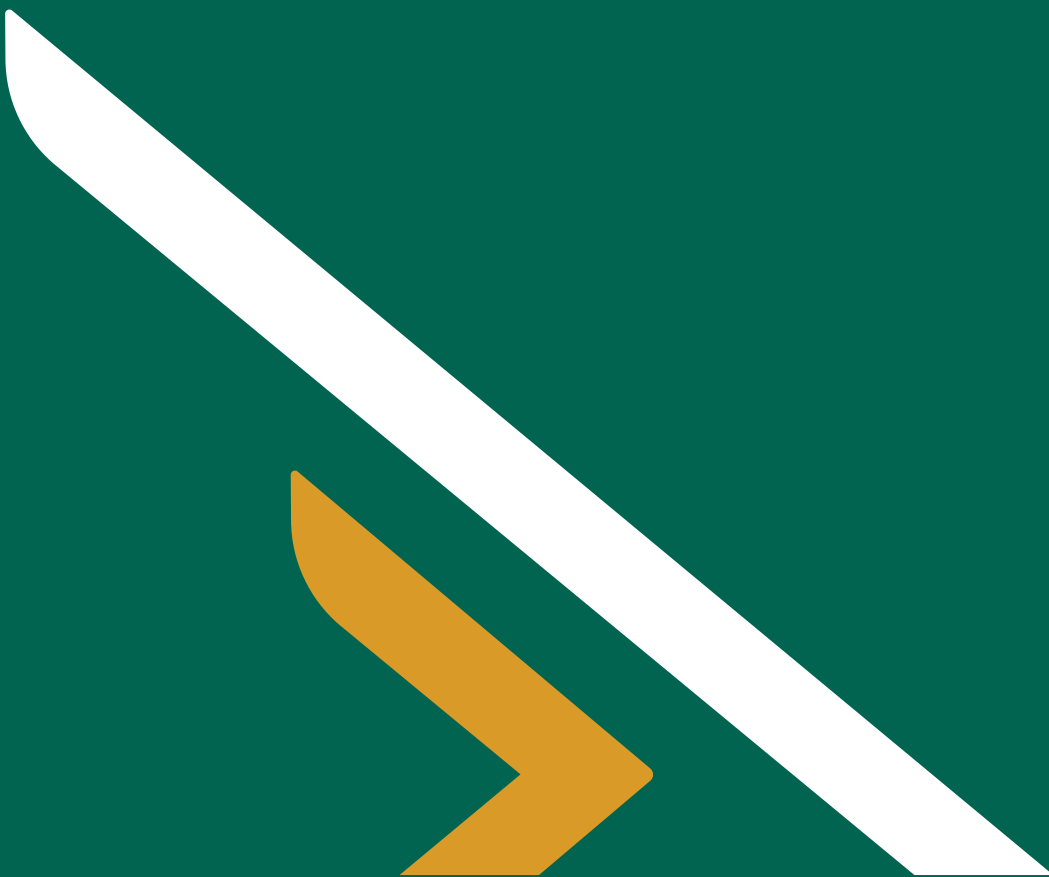

1. What is Transfer Pricing

This Chapter provides an introduction to Transfer Pricing.

- Transfer Pricing refers to the pricing of Transactions between Related Persons. These Controlled Transactions include but are not limited to Transactions related to goods, services, loans and Intangibles.
- Transfer Pricing Bylaws have been put in place to ensure that Related Persons set their prices in a similar way to Independent Persons under comparable circumstances.

2.1. Basic Premise

This introduction gives a brief outline on the definition, the history and background and the possible implications and concerns surrounding Transfer Pricing.

International trade has grown rapidly over the last few decades and the cross-border trade of goods, services, Intangibles and loans by Multinational Enterprises (“MNEs”) has accounted for much of this growth. Consequently, the profile and importance of Transfer Pricing has increased over the years, resulting in the OECD publishing substantial and sustained Guidance on the Arm’s Length Principle as well as the implementation of local Transfer Pricing legislation by many countries.

Transfer Pricing refers to the pricing of Transactions between Related Persons that are part of the same MNE Group. These so-called “Controlled Transactions” include but are not limited to Transactions related to goods, services, loans and Intangibles. The Controlled Transactions could either occur between Related Persons located in the same Tax Jurisdictions or Related Persons located in different Tax Jurisdictions.



Figure 1 - General overview of Controlled Transactions

Arm's Length Pricing (i.e. the pricing for a service/goods/loans or Intangibles which two or more Independent Persons determine according to market forces and Uncontrolled Transactions characteristics) is important for both the Taxpayers as well as tax administrations because it has the potential to influence the revenue and expenses of Persons, and thereby the taxable profits of Related Persons in different jurisdictions. This is especially relevant for MNEs operating in different jurisdictions, which can have different tax laws and tax rates affecting the local operations of the MNE.

Ultimately, the combined impact of the overall pricing of Controlled Transactions has an impact on the amount of profit which is reported in a country, and thus the total amount of taxes to be paid. While Transfer Pricing begins with Controlled Transactions, it ultimately concerns how profits are shared between Related Persons, and thereby between countries.

Since Related Persons are generally not subject to market forces and do not necessarily undertake Arm's Length negotiations, they are potentially able to structure their Controlled Transactions in a Non-Arm's Length way. For the Uncontrolled Transactions, the conditions of their commercial and financial relations are affected by market forces and negotiations, whereby the commercial and financial relations for Controlled Transactions could be affected by a combination of both market as well as group driven forces.

Given the above, TP Bylaws have been put in place to ensure that Related Persons set their prices in a similar way to how Independent Persons would set their prices under comparable circumstances.

2.2. Transfer pricing framework

To determine the Arm's Length Nature of the Controlled Transactions and relationships, various steps need to be undertaken. Each of these steps are further detailed in this Guideline and can schematically be shown as follows:

#	Step	General Consideration
1	Subject	The first step is to identify if the Taxpayer falls within the scope of the TP Bylaws and which Persons qualify as Related Persons. This is further outlined in Chapter 3 of this Guideline.

2	Comparability analysis	Identification and determination	The second step is the identification and delineation of the Controlled Transactions. This can be divided into the following sub-steps:
			<p>i. performing broad-based analyses including the industry sector and other relevant items of the MNE Group such as business strategies, supply chain and key functions assets and risks;</p> <p>ii. identification and determination of the Controlled Transactions. It is necessary to identify these Controlled Transactions and analyse the terms and conditions of the arrangements between the Related Persons.</p> <p>In Chapter 4 the identification and determination process are further outlined.</p>
3		Testing	Based on the comparability analysis, the most appropriate Transfer Pricing Method should be applied to evaluate the Arm's Length Nature of the Controlled Transactions under review. This is further outlined In Chapter 4.
4	Documentation		Each of the steps outlined above should be properly documented to demonstrate the Arm's Length Nature of the Controlled Transactions. This is further outlined in Chapter 5.
5	Implementation		A final step is to properly reflect the Arm's Length terms and conditions in the commercial figures of the Taxable Persons. This is further outlined in Chapter 6.

In addition, specific guidance is included in this Guideline with respect to:

- Financial Transactions (Chapter 7);
- Intangibles (Chapter 8);
- Business Restructuring (Chapter 9);
- The use of valuation approaches (Chapter 10);
- Permanent Establishments (Chapter 11); and
- Audit and risk assessment (Chapter 12).

2.3. Arm's Length Principle

The Arm's Length Principle is the international Transfer Pricing standard that OECD member states and other countries, including the KSA, have agreed should be used for tax purposes by MNEs and tax administrations. These countries have implemented Transfer Pricing legislation that provide explanation and Guidance on the domestic adoption of the Arm's Length Principle. The Arm's Length Principle is defined in the TP Bylaws as follows:



“Where conditions are made or imposed between two or more Related Persons in their commercial or financial relations which differ from those which would be made between Independent Persons, then any profits which would, but for those conditions, have accrued to one of such Related Persons, but, by reasons of those conditions, have not so accrued, may be included in the profits of that person and taxed accordingly.”¹

It applies to both domestic and cross-border Transactions between Controlled Persons

Based on this definition, an Arm's Length Price is generally considered to be the price that would exist if Related Persons to a Controlled Transaction were dealing with each other as Independent Persons. Ideally, the Transfer Price applied between Related Persons should not differ from the prevailing market price which would be used in a Uncontrolled Transaction.

With respect to juridical persons owned by both a Person covered by Article 2 of the Zakat Regulations (issued pursuant to Ministerial Resolution No. 2082 dated 1/6/1438 H) as well as a Person subject to the Income Tax Law, the Arm's Length Principle applies to the extent that the Person is subject to income tax in the Kingdom. These Persons are also referred to as Mixed Companies. An example of this situation is included in Appendix 1.

(1) Article 1(A)(2) of the TP Bylaws.

There could be a risk that Related Persons enter into Controlled Transactions without satisfying or complying with the Arm's Length Principle. Although various reasons could exist for this, this may also be an attempt by the MNE to shift profit between Related Persons (and possibly between different countries) and thereby influencing the effective tax burden in different countries.

For determining the Arm's Length Price of the Controlled Transaction, a detailed understanding is required of the terms and conditions under which the Transaction takes place between the Related Persons to ensure comparability with the Uncontrolled Transaction. In this Guideline the Authority provides further Guidance on how the Arm's Length Principle should be interpreted and applied for the Taxable Persons.

3.

Subjects

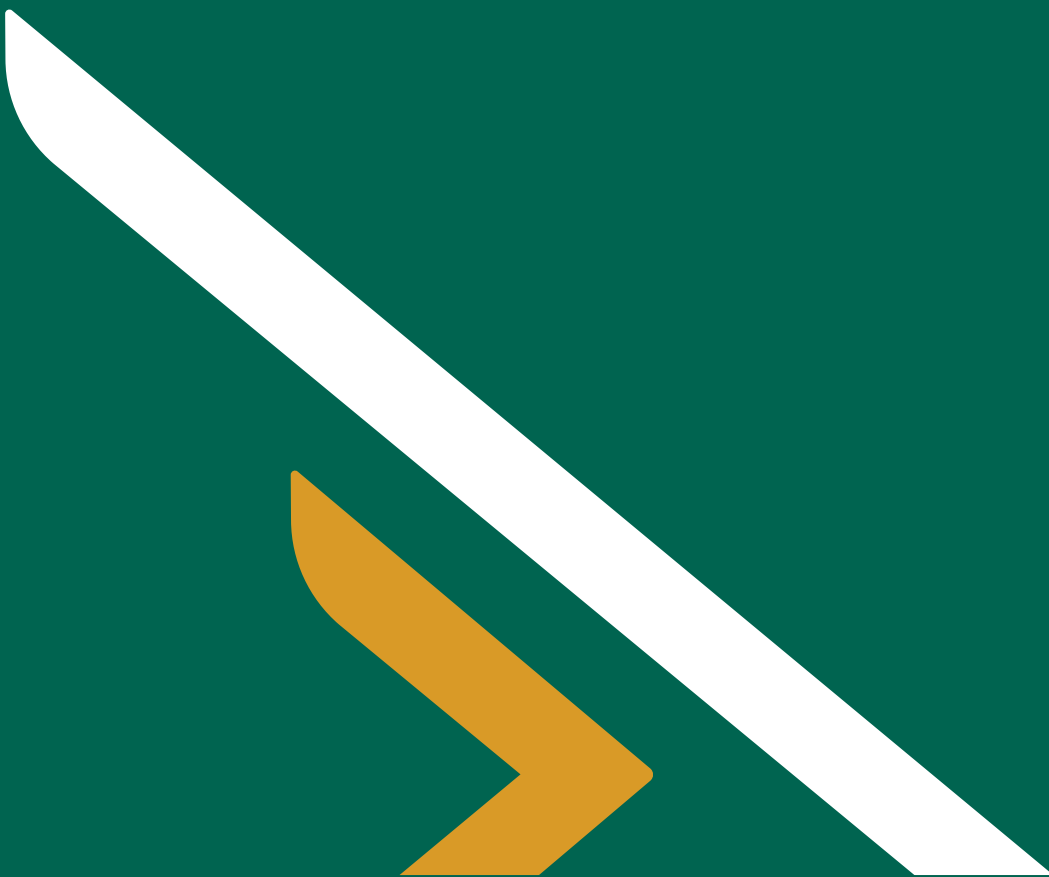

3. Subjects

This Chapter is intended to provide the Persons covered by the scope of the TP Bylaws. The first step in applying the TP Bylaws is to identify whether or not a Person falls within the scope of the TP Bylaws (Paragraph 3.2), and whether or not parties to Transactions are considered Related Persons (Paragraph 3.3). The Chapter addresses the following items:



- The TP Bylaws apply to the Persons as defined in Paragraph 3.2 of the Guideline.
- Each Person that falls within the scope of the TP Bylaws needs to identify to what extent it is involved in Transactions with Related Persons. In short, with regard to Related Persons a distinction could be made between the following two situations:
 - o Related Persons via ownership or shareholding;
 - o Related Persons via Effective Control.



- In both of the situations, control is the key criteria. For Effective Control the underlying premise is that when a Person effectively controls the other Person or both Persons are under Common Control, there is the ability to control the Transactions. The various levels of control can be categorized as follows:
 - o Control via governance;
 - o Control via funding; and
 - o Control via business.

3.1. Persons



TP Bylaws
apply
to

- The TP Bylaws apply to the Persons that are considered to be Taxable Persons according to the Income Tax Law of the Kingdom. This concerns juridical Persons only. A juridical Person includes PEs as well².
- These TP Bylaws also apply for companies that are subject to both Income Tax and Zakat (so called Mixed Companies) but only to the extent that they are subject to Income Tax.



TP Bylaws
do not apply
to

- A juridical person who is subject to Zakat only is not within the scope of Persons covered by the TP Bylaws. However, a juridical person subject to Zakat may be required to comply with the TP Bylaws if the conditions require them to submit the CbCR as per Article 18 of the Bylaws. In this case, the juridical Person subject to Zakat would be subject to the CbCR provisions of the TP Bylaws³.

Example

These TP Bylaws are also applicable to juridical persons subject to both Income Tax and Zakat (“Mixed Companies”) but only to the extent that they are subject to Income Tax. For instance, a company resident in the Kingdom 30% of which is owned by a foreign MNE and 70% owned by a Saudi national company will only be subject to Transfer Pricing with respect to the pro rata part of its income subject to Income Tax (the taxable base). In this example, a Transfer Pricing correction of 100 will result in an income tax correction of 30.

(2) Article 1(A)(22), Transfer Pricing Bylaws.

(3) Article 2, Transfer Pricing Bylaws.

3.2. Related Persons

Each Person that falls within the scope of the TP Bylaws needs to identify to what extent it is involved in Transactions with Related Persons. This is relevant for step 2 of the Transfer Pricing framework to identify the Transactions in scope or in the wording of the TP Bylaws the 'Controlled Transactions'. Note that a Related Person can be both a natural person or juridical Person. In short, with regard to Related Persons, a distinction can be made between the following situations:

1. Other Persons that effectively controls the Person within scope of the TP Bylaws ('Effective Control by Related Person');
2. Other Persons that are effectively controlled by the Person in scope of the TP Bylaws ('Effective Control over the Related Person');
3. Other Persons that are effectively under the same control as the Person in scope of the TP Bylaws ('Effective common Control').

It should be noted that the first two situations might apply to natural persons and juridical persons⁴. However, in practice most situations would involve juridical persons. The below sections therefore focus mainly on juridical persons.

(4) Article 1(A)(25)(a) & (b) , Transfer Pricing Bylaws.

3.2.1. Control via Ownership

The basis of this principle is that control is considered to accompany ownership. These lines of ownership are enumerated in the TP Bylaws⁵. If the ownership in a person is 50% or more, control is considered to be present. This is illustrated in the following examples:

1. A nonresident or resident company that owns directly or indirectly 50% or more in a subsidiary that is within scope of the TP Bylaws ('Control by a Related Person');
2. A nonresident or resident subsidiary of which 50% or more is owned directly or indirectly by a company that is within the scope of the TP Bylaws ('control of the Related Person');
3. Two nonresident or resident Persons (sister companies) where 50% or more of each is owned by the same Person (parent) directly or indirectly ('Common Control').

The ownership threshold of 50% could be met where there is indirect ownership by Related Persons. This is illustrated in the following situation.



Figure 2 - Example 50% indirect ownership via Related Persons

In principle, there is no direct control over Person Z by Person X since the direct ownership in Person Z by Person X does not meet or exceed the 50% ownership threshold. However, via the ownership in Person Y (Related Person), the 50% ownership threshold is indirectly met. Person X owns in total 64% in Person Z (directly 40% and indirectly 24% ($60\% \times 40\% = 24\%$)). Therefore, Persons X, Y and Z are considered to be Related Persons for purpose of the TP Bylaws.

Note that the definition of ownership concerns a broad definition. Besides the actual ownership the definition covers (amongst others) also the right to use and dispose of as an owner, or the ability to own with reasonable certainty the (voting rights) to the income or capital of a Person. The intention of this broad definition is to capture all forms of control via ownership. For example, the situation where the voting rights are not in line with the ownership interest. In such a case, the voting rights should also be considered in determining the ownership percentage.

The intention to capture all forms of control is also reflected in the fact that the TP Bylaws are extended to the situations in which there is strictly no legal ownership but there is Effective Control from an economic point of view.

3.2.2. Effective Control

Effective control is defined in the TP Bylaws as the ability of a Person to control the business decisions of another Person⁶. This concerns a broad definition that includes both legal and economic factors that might result in different levels of control. The various levels of Effective Control can be categorized as follows:

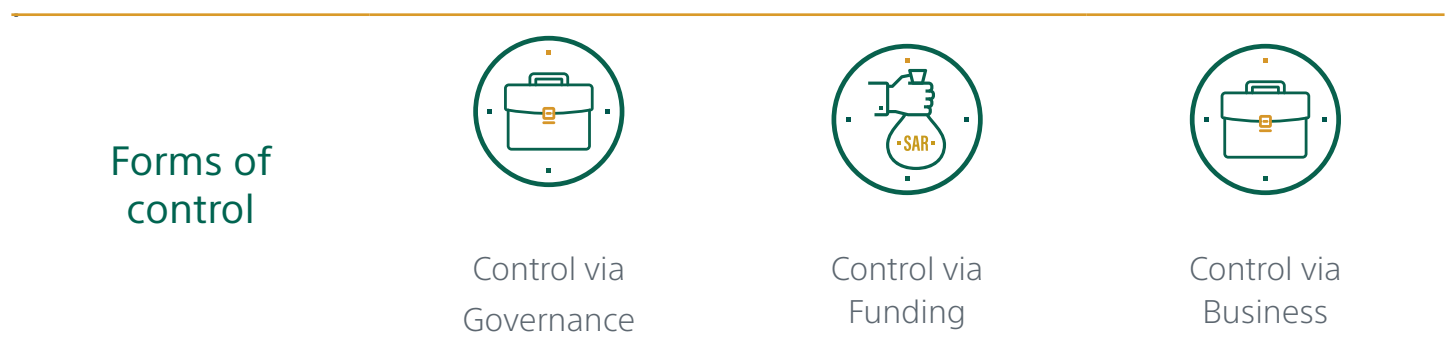

Each category has its own characteristics which are described in more detail below. It should be noted that the described categories and examples are not exhaustive. In practice there may be other situations in which a Person is able to control the business decisions of another person. Based on the facts and circumstances of the case at hand, such a situation could be in scope of the TP Bylaws⁷.

(6) Article 1(A)(12), Transfer Pricing Bylaws

(7) Article 1(A)(12)(k), Transfer Pricing Bylaws.

3.2.2.1. Control via governance

If a Person is granted the power to influence the decisions of the business, it will gain Effective Control. The ability to influence might be obtained through a management agreement, trust arrangement or control on the board of directors.

When a Person engages another Person to run its business it might enter into a management agreement with this Person. This management agreement contains the rights and obligations of both Persons. This gives the Person performing the management services Effective Control over the Person's business decisions (dependent on the scope of the management agreement). If this is the case, there will most likely be Effective Control⁸.

It is also possible for a Person to enter into a trust agreement with another Person. This allows the other Person (trustee) to exercise control over the assets of the other Person (trustor). The trustee might not own the assets it manages, but it may assume some legal obligation to manage the assets diligently and with due care behalf of the other Person. Therefore, although the legal ownership of the assets remains with the trustor, the trustee's position may allow him sufficient authority to act in such a way that is tantamount to controlling the business decisions of the trustor and hence, have Effective Control over this Person⁹.

If a Person has the power to composite 50% or more of the board of directors, either directly or indirectly, it will be presumed that he has the ability to control the business decisions of that Person. Usually, appointed board directors are able to influence the policy and decision making of a juridical person such as a company. Therefore, the ability to appoint 50% or more of the board of directors of a company is a strong indicator that such Person Effectively Controls that company¹⁰. As an example, in a situation in which a Person owns less than 50% of a company's shares but is able to appoint more than 50% of the board of directors of that company and is in fact in control of their votes, this company is considered a Related Person to him as a result of his Effective Control.

(8) Article 1(A)(12)(a), Transfer Pricing Bylaws.

(9) Article 1(A)(12)(b), Transfer Pricing Bylaws.

(10) Article 1(A)(12)(c), Transfer Pricing Bylaws.

3.2.2.2. Control via funding

Notwithstanding that control of the business decision is exercised via the actual decision-making process, there could also be control over the decision making via funding from an economic point of view. This can occur through debt or equity capitalization (or both).

When a Person is funded through equity, in general, this goes along the lines of ownership. The provider of equity is generally remunerated via profit distributions. The entitlement to the profit expressed in percentages is in most cases aligned with the percentage of ownership. However, it could be the case that the ownership of a Person is below the 50% threshold, but this Person is entitled to at least 50% of the profits of the other Person. Therefore, when a Person is entitled to 50% or more of the profits, this Person is presumed to have the ability to control the business decisions, and hence Effective Control¹¹. The 50% threshold needs to be applied in a similar manner to the 50% ownership threshold. As such, the threshold of 50% could also be met indirectly via Related Persons. Reference is made to the example in Paragraph 3.3.1. 'control via ownership'.

When a Person is funded through debt, in practice a creditor will negotiate some level of security which could result in the ability to control certain business decisions of the debtor. In this case it is important to understand the creditor's proportion of the total outstanding debt of the Person it funds. If this amounts to 50% or more of the total book value comprising of long term debt, short term debt and capital excluding retained earnings, it is considered that the creditor has the ability to control the business decisions of the Person¹². The assessment of the proportion of debt is illustrated with the following example.

(11) Article 1(A)(12)(d), Transfer Pricing Bylaws.

(12) Article 1(A)(12)(e), Transfer Pricing Bylaws.

Example

Company X has total assets of SAR 125 million. These are funded with equity and debt. X's equity amounts to SAR 40 million including SAR 15 mn in retained earnings. The total outstanding debt amounts to SAR 85 million comprising of SAR 60 million long term debt to Company Y (creditor) a limited liability company that carried out industrial activity, and a current account position of SAR 25 million with a banking institution.

Company (X)			
Assets		Liability	
PPE	75	Capital Stock	25
Other	50	Retained Earnings	15
		Current account	25
		Dept Company (y)	60
Total Assets	125	Total Liability	125



Based on the example above, the book value of the outstanding balance of the debt owed to Company Y amounts to 55% of the total book value of the outstanding debt of Company X $(60 / (85 + (40 - 15)) * 100)$. Thus, in this case it is presumed that Company Y has Effective Control over Company X.

Instead of providing a loan, a Person can also provide a guarantee for a loan. In general, such guarantee ensures that if a Person is not able to meet its debt obligations, the other Person (guarantor) will cover the Person's debt obligations. If a guarantor guarantees to cover a Person's debt and this consist of 25% or more of the total borrowings of that Person, then the guarantor is considered to have Effective Control over that Person¹³. This is illustrated in the following example.

(13) Article 1(A)(12)(f), Transfer Pricing Bylaws.

Example

When Person Z as guarantor provides a guarantee for the current account position of Person X, the guarantee amounts to 29% ($25/85 \times 100$). This is more than the required 25% and therefore the guarantor is considered to have Effective Control over Person X.

The above-mentioned ways of gaining effective control over another Person do not apply for Financial Institutions¹⁴.

The Bylaws define Financial Institutions as a juridical person, the substantial and primary business of which is to conduct banking, financing or both, and that is regulated by one or more central government agencies responsible for licensing and supervising it in jurisdictions in which it operates¹⁵. In respect of Persons licensed to provide services in the Kingdom, GAZT considers a Financial Institution to be those deemed to be "Banks"¹⁶ or "Financing Companies"¹⁷ subject to regulation by the Saudi Arabian Monetary Authority or any other government agency in accordance with the laws and regulations in the Kingdom. As for institutions not authorized to provide services in the Kingdom and not subject to the regulatory jurisdiction of the Kingdom, the term means a juridical Person considered a bank or a financing company in the jurisdiction in which such Person carries out activities and whose activities and purpose are substantially similar to those of institutions that would be considered a bank or financing company under the laws and regulations of the Kingdom, and provided that such Person is licensed in that other jurisdiction to conduct such banking or financing activities (as the case may be) and is regulated by an agency of the central government of such jurisdiction such as the treasury or central bank in a manner similar to the way it would have been regulated in the Kingdom had it been subject to the regulatory jurisdiction of the Kingdom.

Therefore, a banking institution could not become a Related Person in case it provides loans and/or issues guarantees.

(13) Article 1(A)(12)(f), Transfer Pricing Bylaws.

(15) Article 1(A)(13), Transfer Pricing Bylaws.

(16) See Article 1, Definitions, Banking Control Law.

(17) See Article 1, Definitions, Finance Companies Control Law.

3.2.2.3. Control via business

Certain Persons do business with only one or few other Persons (customers). It is possible that a Person is to a certain extent dependent on the relationship with its customer. This may result in the situation that the customer could have the ability to exercise control over the Person. The threshold is considered to be 50%. If a Person engages in Transactions with one of its customers and the aggregated value of the Transactions with this customer comprises 50% or more of the Person's aggregated absolute value of all Transactions), the customer is considered to have control over the Person's business decisions¹⁸.

It is also possible that a Person performs sales activities on behalf of another Person. This could be the case for an agency or distributorship arrangement. This Person does not perform any other activities besides the sale of the products received from its principal. If this is the case then this allows the principal to set the terms and conditions of the contract with the Person and thus creating a highly dependent relation. Therefore, when this Person is prohibited from entering into other similar agency or distributorship arrangement, Effective Control over the business decisions of the Person is presumed¹⁹.

Example

A reseller of phones exclusively has the right to only sell a certain type of phone. This right is given to him by a distributor. The reseller is prohibited from entering into other similar arrangements. Therefore, the distributor would have the ability to control the business decisions of the reseller.

(18) Article 1(12)(g), Transfer Pricing Bylaws.

(19) Article (1)(12)(i), Transfer Pricing Bylaws.

4.

Comparability Analysis: Identification and Determination

4. Comparability analysis: identification and determination

A comparability analysis should be carried out to identify and accurately isolate the functional and economically relevant characteristics of the Controlled Transaction. It is necessary to review the possible sources of comparable information, both from internal and external sources. When evaluating the comparability of an Uncontrolled Transaction to a Controlled Transaction, all factors affecting prices or profits must be considered. Further guidance on these comparability factors is included in this Chapter. Ultimately, the goal of this analysis is to assess to what extent the Controlled Transactions and Uncontrolled Transactions are truly comparable. This is referred to as the comparability analysis, which is a key aspect of the application of the Arm's Length Principle.

In this analysis, there are two key aspects to consider:



The first aspect (macro analysis of the Person) focusses on the identification of the commercial and financial relations between the Related Persons. Further, it should be identified what conditions and economically relevant circumstances are attached to those relations between the Related Persons. In this way, the Controlled Transaction can be accurately characterized for purposes of determining the most accurate Arm's Length Price for that Transaction (also known as "accurately delineating the transaction"); and



The second aspect (micro analysis of the comparables) focusses on the conditions and the economically relevant circumstances of the Controlled Transactions (that is isolated) compared to the conditions and economically relevant circumstances of Comparable Transactions between Independent Persons.

These two key aspects should be analyzed separately, as the first aspect is focused on accurately isolating the Controlled Transaction while the second aspect focuses on the application of the Arm's Length Principle to the Controlled Transaction between the Related Persons.

After the review of the potential comparable information, the most appropriate Transfer Pricing Method needs to be selected based on the available comparable information and the reliability of that information in applying the selected Transfer Pricing Method. In applying the Method, it is normally necessary to consider performing comparability adjustments to reduce the material differences (if any) between the situations being compared. In this respect, if material differences exist between the Controlled and Uncontrolled Transactions that could materially affect the outcome of the Transfer Pricing analysis, it should be assessed whether these comparability adjustments could be reliably imposed otherwise the Uncontrolled Transaction cannot be used as comparable.

Thus, in accordance with the above, the following three subsequent steps could be distinguished when performing a comparability analysis:



Figure 4 - Steps to comparability analysis

4.1. Step 1: Identification of the Controlled Transaction

4.1.1. Broad-based analysis

The broad-based analysis ensures a better understanding of the MNE and the actual situation of the Related Persons and facilitates the selection process of finding comparables to evaluate the Arm's Length Nature of the Controlled Transactions. The broad-based analysis is further outlined in below sub-Paragraphs.

4.1.1.1. Industry sector

To understand the economically relevant circumstances in connection to the commercial and financial relations between Related Persons, an understanding of the industry sector in which the group of the Taxpayer operates is required (e.g. mining, pharmaceutical, luxury goods). Other relevant factors to consider are those that affect the performance of businesses operating in the determined sector. These industry sector circumstances can be considered in more detail by assessing what the relevant factors are for the business of the Related Person (further guidance is provided in sub-Paragraph 4.1.1.2.).

4.1.1.2. General analysis of the business of the Related Persons

For the identification of the commercial or financial relations and the conditions and economically relevant circumstances attaching to those relations, a broad understanding is required of the industry sector in which the MNE operates. It is important to have a clear overview of the factors affecting the performance of any business operating in that sector. This relevant information for identifying the commercial and financial relations can be derived by having an overview of the following items:

- Business strategies applied;
- Markets in which the Related Persons operate;
- Industry practices;
- Characteristics of the products transferred, or services provided by the Related Persons;
- The supply chain;
- A high-level overview of the key functions performed, assets used, and risks assumed by each of the Persons involved in the Controlled Transaction, including explanation of how these functions relate to the wider generation of value by the MNE Group of which the Related Persons are part.

After obtaining a better understanding of the MNE itself, the process focusses both on the identification on how each Person operates, and also an analysis of the economic role that each Related Person performs within the MNE. For instance, the Person could be engaged in procurement, sales or manufacturing activities within the MNE and their role could be different depending on its functional profile.

Additionally, the analysis requires an assessment and identification of the commercial or financial relations with the Related Persons as expressed in the Controlled Transactions between them. Such information can be, for example, obtained from written contracts or any other written documents which provide more background on the Transactions between the Related Persons (e.g. in e-mails, file notes, etc.).

The above analysis safeguards that the role of the Persons within the MNE is separately analyzed, and also identifies the existing commercial and financial relationship between the Related Persons, taking into account the conditions and economically relevant characteristics. This information is then used for determining the conditions that Independent Persons would have agreed upon if they were engaged in Comparable Transactions under comparable circumstances. This information is crucial for being able to make comparisons with Transactions that occur between Independent Persons.

4.1.2. Controlled Transaction(s)

Once a broad-based analysis is performed, a more in-depth analysis should be performed on the Controlled Transaction(s).

The scope of the TP Bylaws covers the Controlled Transaction made between Related Persons in the same Tax Jurisdictions as well as foreign Tax Jurisdictions. In accordance with Chapter 1 of this Transfer Pricing Guideline, the Controlled Transactions that are in scope of the TP Bylaws are Transactions related to goods, services, loans and Intangibles. No exemptions are made in these TP Bylaws regarding specific items that do not fall under the scope of the Bylaws. As such, the definition of Controlled Transaction is intended to be wide in nature.

The information on the economically relevant characteristics of the Controlled Transactions should be included within the Transfer Pricing documentation prepared by the Taxpayer. This information should be part of the Local File requirements of the KSA which will be explained in further detail in Chapter 5 of this Transfer Pricing Guideline.

4.1.2.1. Identification of operations and commercial or financial relations with Related Persons

For the application of the Arm's Length Principle to the Controlled Transaction, it is important to determine the economically relevant terms and conditions. These economically relevant terms and conditions are to be compared to the conditions that would have existed if the Persons were operating independently and undertaking a Comparable Transaction under comparable circumstances.



Relevant Comparability Factors

Relevant comparability factors that need to be considered to make this comparison between the Controlled and Uncontrolled Transactions are:

1. Determine the contractual terms of the Transaction;
2. Functional Analysis for each Related Person part of the Controlled Transaction;
3. Analysis of risks relevant to the Controlled Transaction;
4. Characteristics of the property transferred, or services provided;
5. The economic circumstances of the market in which the Related Persons operate; and
6. Business strategies pursued by the Related Persons.

Guidance on these relevant comparability factors is included in the below sub-Paragraphs.

Comparability factor (i): Determine the contractual terms of the Transaction

When a Transaction has been formalized by the Related Persons through written contractual agreements, those agreements should provide the starting point for determining the Transaction between them and how the responsibilities, risks, and anticipated outcomes arising from their interaction were intended to be considered at the time of entering into

the contract. The terms of a Transaction may also be found in communications between the Persons other than in a written contract (e.g. in e-mails and other correspondence).

Comparability factor (ii): Functional analysis for each Person in the Transaction

Written contracts alone are unlikely to provide all the information necessary to perform a Transfer Pricing analysis, or to provide information regarding the relevant contractual terms in sufficient detail. Generally, additional information will be required by taking into consideration evidence of the commercial and financial relations provided by the economically relevant characteristics of the Related Persons. If the characteristics of the Controlled Transaction that are economically relevant are inconsistent with the written contract between the Related Persons, the economic substance of the Transactions should instead be considered in the Transfer Pricing analysis. This should be in accordance with the characteristics of the Transaction reflected in the actual conduct of the Persons to isolate the Controlled Transaction to be priced.

The Functional Analysis forms a key part of identifying the actual conduct of the Related Persons. The Functional Analysis seeks to identify the economically significant activities and responsibilities undertaken, assets used or contributed, and risks assumed (see also Comparability factor iii for additional guidance) by the Persons part of the Controlled Transactions.

On a practical note, when conducting a Functional Analysis, a functional organization chart could be prepared for each of the Persons participating in the Controlled Transaction. This functional organization chart should identify the relevant departments and personnel within the Person and the functions they perform. For the personnel, stating the title is not sufficient; information is required on the function performed (e.g. via job description) and the actual conduct of such personnel, on the way the compensation is structured etc.

Below a sample list of questions is included that may be considered relevant for performing the Functional Analysis for a Person involved in Sales and Distribution activities. This list is not intended to be exhaustive and should be amended to cover the relevant aspects of the specific Industry sector and Controlled Transaction being analyzed.

Sales and Distribution

Sales	<ul style="list-style-type: none"> • What is the sales process? • Which Person issues the invoice to the customer? • Which employees determine the projects and set the sales targets? If this is done by multiple employees in the Transaction, please describe the role of each of these employees. • Who is responsible for achieving the sales targets? • Which employees negotiate the sales contracts with customers? • What are the risks related to the demand of the products and which employees manage such risk? • Which decisions require approval by other employees/ employees of other Persons?
Quality Control	<ul style="list-style-type: none"> • What form of quality control is applicable? • Which employees set the quality standards and procedures? • Who performs and bears the costs for the quality control? • How many products are rejected by customers due to 'below standard'? • Which Person bears the loss in relation to defective products?
Inventory	<ul style="list-style-type: none"> • Where and how is stock held? • Which Person/employees control(s) the levels of inventory? • Are purchases made on consignment (i.e. legally owned by one Person, held by another Person)? • How many days of inventory are in general applicable? What happens with excess stock and which Person bears the risks relating to excess stock?
After-sales services	<ul style="list-style-type: none"> • Does the Person provide after-sales services? If being the case, describe this service. • Is one of the Persons providing product guarantees and which Person manages this risk? • Which Person bears warranty costs?

For other types of Transactions different questions and attention points may be relevant when performing a Functional Analysis and thereby identifying the economically significant activities and responsibilities undertaken, assets used or contributed, and risks assumed of the Related Persons involved.

Comparability factor (iii): Analysis of risks

The analysis of risk can be seen as an integral part of the Functional Analysis. For clarity purposes this key element is addressed separately as it is an important consideration for understanding the commercial and financial relationships between Persons engaged in a Controlled Transaction. The following six-step process could be distinguished to determine how the Persons allocated the risks amongst them within the Controlled Transaction:



1 Determine how specific, economically significant risks are contractually assumed;

2 Determine how the Related Persons engaged in the Transaction operate in relation to assumption and management of the specific, economically significant risks;

3 Determine whether the contractual assumption of risk is consistent with the actual conduct of the Related Persons. In this respect, in general risk should follow the functions performed;

4 When the Person assuming the risk under steps 1-4 does not control the risk or does not have the financial capacity to assume the risk, then the risk must be allocated to the Person or Persons that actually control the risk and have the financial capacity to assume the risk; and

5 Price the actual Transaction as accurately isolated by taking into account the financial and other consequences of risk assumption.

Comparability factor (iv): Characteristics of the property transferred, or services provided

Differences in the specific characteristics of property or services often account, at least in part, for differences in their value in the open market. Therefore, comparisons of these features may be useful when isolating the Controlled Transaction and thereby in determining the comparability of the Controlled and Uncontrolled Transactions. Characteristics that may be important to consider include the following:

tangible property

In the case of transfers of tangible property, the physical features of the property, its quality and reliability, and the availability and volume of supply;

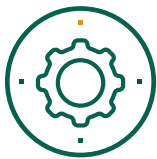

Characteristics

provision of services

In the case of the provision of services, the nature, value and extent of the services; and

Intangible property

In the case of Intangible property, the form of the Transaction (for example, licensing or sale), the type of property (such as patent, trademark, or know-how), the duration and degree of protection, and the anticipated benefits from the use of the property.

Comparability factor (v): The economic circumstances of the market in which the Persons operate

Arm's Length Prices may vary across different markets, even for Transactions involving the same property or services. Therefore, achieving comparability requires that the markets in which the Independent and Related Persons operate do not have differences that have a material effect on the price or, if there are differences, that appropriate adjustments can reliably be made.

It is essential to identify the relevant market or markets, taking into account the availability of substitute goods or services. Economic circumstances that may be relevant to determining market comparability include:

- geographic market including: the size of the markets; the extent of competition in the markets and the relative competitive positions of the buyers and sellers; the availability (risk thereof) of substitute goods and services; the levels of supply and demand in the market as a whole and in particular regions, if relevant; consumer purchasing power in the market; the nature and extent of government regulation of the market; costs of production, including the costs of land, labor, and capital; transport costs in the market;
- the level of the market (e.g. retail or wholesale);
- the date and time of Transactions; and
- the existence of a cycle (for instance, economic, business, or product cycle).

The facts and circumstances of the particular case will determine whether differences in economic circumstances have a material effect on price and whether reasonably accurate and reliable adjustments can be made to eliminate the effects of such differences.

Comparability factor (iv): Business strategies pursued by the Persons

Business strategies would take into account many aspects of a Person, such as innovation and new product development, degree of diversification, risk aversion, specific marketing strategies, assessment of political changes, input of existing and planned labor laws, duration of arrangements, and other factors bearing upon the daily conduct of business. Such business strategies may need to be taken into account when determining the

4.2. Step 2: Selection of TP Method

As a next step, after sufficiently identifying the Related Persons and Transactions under review, an appropriate Transfer Pricing Method should be applied to test the Arm's Length nature of the Controlled Transactions. To determine and evaluate the Arm's Length Nature of the Controlled Transactions, five Transfer Pricing Methods could be used for testing as approved by the TP Bylaws. The comparability analysis performed forms the basis for selecting the most appropriate Transfer Pricing Method to test the Arm's Length Nature of the Controlled Transactions.

There are two broad categories of Transfer Pricing Methods recognized: the "Traditional Transaction Methods" and the "Transactional Profit Methods". These Transfer Pricing Methods could be used to establish whether the conditions imposed in the commercial or financial relations between Related Persons are consistent with the Arm's Length Principle.

The traditional transaction methods are:	Comparable Uncontrolled Price Method "CUP"	Resale Price Method "RPM"	Cost Plus Method ("C+ Method")
The transactional profit methods are:	Transactional Net Margin Method "TNMM"	Transactional Profit Split Method ("PSM").	

The aforementioned methods are further discussed in this Chapter.

The goal of selecting a Transfer Pricing Method is to find the most appropriate method for a particular case. In the selection process of finding the most appropriate Transfer Pricing Method, the following factors are taken into account:



Factors to
choose the
appropriate
method for PT

1. The respective strengths and weaknesses of the Approved Transfer Pricing Methods;
 2. The appropriateness of the Method considered given the nature of the Controlled Transaction. The nature of the Controlled Transactions could be determined through a Functional Analysis;
 3. The availability of reliable information (in particular on Uncontrolled Transactions) needed to apply the selected Approved Method (or other TP Methods)²⁰. It is especially important to assess whether publicly available data can be drawn from commercial databases or other public available sources; and
 4. The degree of comparability between Controlled and Uncontrolled Transactions, including the reliability of comparability adjustments that may be needed to eliminate material differences between them.
-

All the factors that are described (e.g. strengths and weaknesses of the Transfer Pricing Method) must be considered to evaluate which Transfer Pricing Method could be seen as most appropriate for a particular case.

(20) Article 9, Transfer Pricing Bylaws.

Traditional Transaction Methods are regarded as the most direct means of determining whether conditions in the commercial and financial relations between Related Persons are Arm's Length.

If a Traditional Transaction Method and a Transactional Profit Method can be applied in an equally reliable manner, the Traditional Transaction Method is generally preferable to the Transactional Profit Method. The reason for this is that any difference in price of a Controlled Transaction compared to the price in a comparable Uncontrolled Transaction could be directly traced to the terms governing the commercial and financial relationship between the Related Persons. As a consequence, the Arm's Length conditions can be established by directly substituting / using the price/margin in the identified comparable Uncontrolled Transaction for the price/margin of the Controlled Transaction.

If the Traditional Transaction Methods are not considered to be the most appropriate methods, it may be considered to select a Transactional Profit Method as the most appropriate method. A Transactional Profit Method examines the profits that arise from particular Controlled Transactions. There are two transactional profit methods: the TNMM and the PSM.

The appropriateness of applying transactional profit methods may be considered depends on the facts and circumstances. The TNMM is unlikely to be reliable if each Person to a Transaction makes unique and valuable contributions. In case each of the Persons makes unique and valuable contributions the PSM may be considered more appropriate. Paragraphs 4.2.4. and 4.2.5. provide further guidance on these specific Methods.

Furthermore, the Transactional Profit Methods could also be preferable to the Traditional Transaction Methods if there is no or limited publicly reliable data (due to differences in accounting standards or accounting policies) on the treatment of expenses or revenues which determine the gross margin in comparable Uncontrolled Transactions. As will be further explained in the following Paragraphs, the price/gross margin is the starting point to use the Traditional Transaction Methods, but getting sufficient comparable Transactions with no or limited data is frequently difficult in practice.

Nonetheless, the rationale to use the Transactional Profit Method cannot be based merely on the fact that data is difficult to obtain. Again, all the factors that are described earlier (e.g. strengths and weaknesses of the transfer pricing method) must be considered to evaluate which Transfer Pricing Method could be seen as most appropriate for a particular case.

Based on the TP Bylaws, a method not described in the Paragraphs below may be applied provided that it satisfies the Arm's Length Principle and represents the most appropriate and reliable Method.

Once the appropriate Transfer Pricing Method is selected and reliable comparables are found (practical Guidance is included in Paragraph 4.3.), an Arm's Length Range can be calculated (e.g. a range with external CUP price or a range of operating margins under the TNMM). To prevent the impact of outliers and exceptional circumstances, a statistical approach to the Arm's Length Range is required. In this respect the interquartile range is considered an appropriate approach to determine an Arm's Length Range of margins.

The interquartile range is obtained by dividing the dataset in four (4) equal parts. By doing so, three unique points amongst the dataset are derived, namely the lower quartile (the middle number/figure between the lowest value and the median), the median (the middle value of all observations) and upper quartile (the middle number/figure between the median and the highest value). The interquartile range then represents all data between the lower quartile and the upper quartile (see figure below).

Interquartile Range

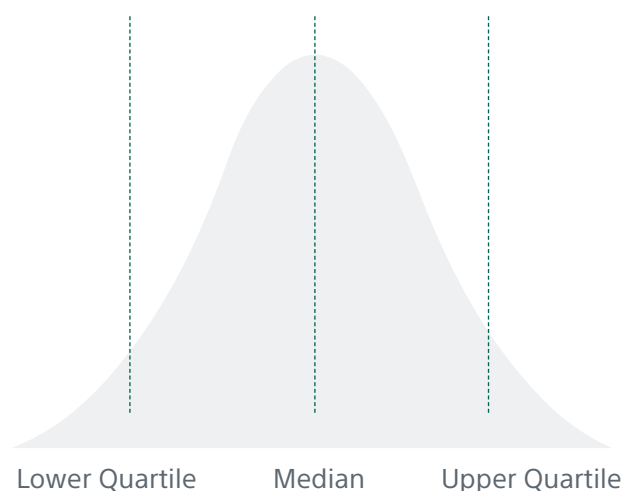

Figure 5 - Illustration Interquartile range

The interquartile range eliminates the extreme values and is less volatile than the full range, i.e. the interval between the minimum and the maximum. Below an example is included on the set of comparables found when performing a benchmark study:

Example:

Number of observations	Observation 1	Observation 2	Observation 3	Observation 4	Observation 5
Percentage	1%	5%	3%	6%	8%

Minimum	Lower Quartile	Median	Upper Quartile	Maximum
1%	3%	5%	6%	8%

Based on the example as depicted above, the benchmark study of the five observations of Uncontrolled Transactions results in an interquartile range from 3% to 6% with the median being 5%. Further, note that the total number of observations in this example is solely indicative. In a benchmark study sufficient observations should be included to properly determine the interquartile range as well as the median value.

Generally, any point within this interquartile range should be considered in line with the Arm's Length Principle. However, unless properly substantiated otherwise, the Authority expects that the median point is used when determining the Transfer Pricing Policy.

Finally, all steps and substantiation should be properly documented in accordance with Chapter 5 of this Transfer Pricing Guideline.

4.2.1. Comparable Uncontrolled Price Method

4.2.1.1. Definition

The CUP compares the price charged for property or services transferred in Controlled Transactions to the price that is charged in comparable Transactions under comparable circumstances.



Definition

An Uncontrolled Transaction is comparable to a Controlled Transaction for purposes of the CUP if:

- None of the differences (if any) between the Transactions being compared or between the Persons undertaking those Transactions could materially affect the price in the open market; or
 - Reasonably accurate adjustments can be made to eliminate the material effects of such differences.
-

4.2.1.2. Explanation and numerical example



Explanation and numerical example

For the application of the CUP, two different CUPs could be identified:

1. the “internal CUP”: The internal CUP could be applied if the Taxpayer engages in Comparable Transactions between Related and Independent Persons; and
2. the “external CUP”: For the external CUP, data of Transactions between two Independent Persons that are sufficiently comparable given the specific circumstances and economically relevant characteristics to the Transaction between the Related Persons can be found and used to test the Arm’s Length Nature.

A general example of using the CUP Method is included in Appendix 2.

4.2.1.3. Best use scenario and adjustments to be considered

When it is possible to identify comparable Uncontrolled Transactions, the CUP is generally the most direct and reliable way to apply the Arm's Length Principle. Under these circumstances, the CUP is preferable over all the other Transfer Pricing Methods prescribed in this Chapter.

More specifically:

- The CUP requires a high degree of comparability of products and functions. For example, a minor difference in the property transferred in the Controlled Transaction compared to the Uncontrolled Transactions could materially affect the price, even though the nature of the business activities undertaken may be sufficiently similar to generate the same overall profit margin. If this situation arises, some adjustments will be appropriate, if they are possible. The extent and reliability of such adjustments will affect the relative reliability of the analysis under the CUP.
- The CUP is in general suitable for establishing an Arm's Length Price for the transfer of commodities between Related Persons. The specific price of these commodities, named the quoted price, could be obtained from an international or domestic commodity exchange market. In principle, it should be assessed whether the quoted price is widely and routinely used in the ordinary course of business in the industry and as such is appropriate to use for pricing the Controlled Transaction. Furthermore, for the application of the CUP to commodity trading, it should be ensured that the economically relevant characteristics of the Controlled and Uncontrolled Transactions are comparable. For instance, prompt delivery of the commodities could lead to a premium or a discount regarding the quoted price. For an overview of the economically relevant characteristics that should be taken into account, reference is made to Paragraph 4.1.1.2.



**Best use
scenario and
adjustments
to be
considered**



**Best use
scenario and
adjustments
to be
considered**

- For commodity Transactions the CUP may be considered useful. Quoted commodity prices generally reflect the agreement between independent buyers and sellers in the market on the price for a specific type and amount of commodity, traded under specific conditions at a certain point in time. A relevant factor for using the quoted price is that such quoted price is widely and routinely used in the ordinary course of business in the industry to negotiate prices for Uncontrolled Transactions. If the quoted price is considered relevant to the Transaction, it is important that the application of the appropriately selected quoted price is applied consistently. For commodities, the economically relevant characteristics include, among others, the physical features and quality of the commodity; the contractual terms of the Controlled Transaction, such as volumes traded, period of the arrangements, the timing and terms of delivery, transportation, insurance, and foreign currency terms. For some commodities, certain economically relevant characteristics (e.g. prompt delivery) may lead to a premium or a discount.
 - o In determining the Arm's Length Price or price range, the standardized contracts which stipulate specifications on the basis for the traded commodities may be relevant;
 - o In case of differences between Conditions of the Controlled Transaction and the conditions of the Uncontrolled Transaction or the conditions determining the quoted price for the commodity that materially impacts the price of the commodity Transactions reasonably accurate adjustments should be made to ensure that the economically relevant conditions are comparable. Moreover, contributions in the form of functions performed, assets used, and risks assumed by other Persons of the MNE Group should be remunerated on an Arm's Length basis.
 - o If no proof of the pricing date is provided by the Taxpayer, the deemed pricing at the shipment date shall be considered the starting point of the analysis. However, the Authority may take a different view on what should be considered the appropriate price date and conditions in relation to the commodity based on the fact and circumstances.



**Best use
scenario and
adjustments to
be considered**

- o Quoted prices may be obtained from public markets trading in commodities. In this respect, Domestic or specific regional information may be important for selecting the quoted prices. Public information may prove to be helpful for pricing Transactions between Related Persons. Differences in commodity features may result in a premium for quality or availability of the specific commodity, e.g. different processing functions performed or required on the commodity, or additional costs incurred for transportation, insurance or foreign currency terms, etc. These elements should be considered (and adjusted for if deemed appropriate) to increase the comparability between the Controlled Transaction and Uncontrolled Transaction.
 - o When the CUP is used on Transactions involving commodities this may involve potential implications in verifying the pricing date to be selected. In practice, the physical delivery date may be in the future (from when the order is placed) whereby in other situations instant delivery may be offered (which may attract a premium). Between the actual date of ordering the commodity and the date that the commodity is physically delivered, a price fluctuation may have occurred.
 - o When applying the CUP, it is important to have a consistent approach on how the quoted price is determined and applied for similar circumstances. This relates to the quoted price used as a basis as well as the comparability adjustments applied. Having a fixed CUP (including fixed quotes price date) throughout the year is not considered to meet the arm's length conditions unless the appropriateness of this fixed price can be substantiated.
-

Example:

As an example, Related Person 1 (located in a foreign country) orders 100 tons of aluminum from Related person 2 (located in the KSA) on March 1.

In this example, only one price per date is provided for illustration purpose whereby in practice a range of prices may be part of the analysis. The aluminum is eventually shipped on May 1 to Related Person 1. The aluminum price on a public market trading in commodities (which is commonly used within the industry to determine prices) on March 1 is SAR 2m per ton. On May 1 the aluminum price is SAR 2.5m per ton. The aluminum of the Controlled Transaction has product differences compared to the 'general' aluminum used to determine the quoted price, the differences is a premium of 10% compared to the aluminum price listed on the public market. The Authority would consider the quoted price of May 1 as a starting point for pricing of the CUP. In addition, a comparability adjustment would be required to determine the appropriate price under similar conditions. Thus, for this specific Controlled Transaction the price per ton would be $SAR 2,500,000 \times 1.1 = SAR 2,750,000$. The Taxpayer may provide evidence to substantiate a different quoted price to be used.

4.2.2. Resale Price Method

4.2.2.1. Definition



Definition

The RPM evaluates whether the amount charged in a Controlled Transaction is at Arm's Length by taking into consideration the gross margin that is realized in comparable Uncontrolled Transactions.

4.2.2.2. Explanation and numerical example



Explanation and numerical example

The starting point for the RPM is the price at which a product has been purchased from a Related Person and hereafter is resold to an Independent Person.

This price (the resale price) is then reduced by an appropriate gross margin (the "resale price margin"). This gross margin represents the amount from which the reseller would seek to cover its selling and other operating expenses and, considering the functions performed (taking into account assets used and risks assumed), makes an appropriate return at the gross profit level.

The remaining amount left after subtracting the gross margin can be regarded, after adjustment for other costs associated with the purchase of the product (for example, customs duties), as an Arm's Length Price for the original transfer of property between the Related Persons.

Appendix 3 includes an example of the RPM.

4.2.2.3. Best use scenario and adjustments to be considered

This method is generally most useful when it is applied to distribution and marketing operations performed by Related Persons.

For the application of the RPM, either internal or external comparables may be used. The internal comparable refers to the resale price margins earned by the reseller in the Controlled Transaction, compared to the resale price margins earned by the same reseller on items purchased and sold in comparable Uncontrolled Transactions. Alternatively, the resale price margins earned by an Independent Person in comparable Uncontrolled Transactions may be used, which is the external comparable.

The RPM depends on comparability of functions performed taking into account assets used and risks assumed. An Uncontrolled Transaction is comparable to a Controlled Transaction for purposes of the RPM if:

- None of the differences (if any) between the Transactions being compared or between the Persons undertaking those Transactions could materially affect the price in the open market; or
- Reasonably accurate adjustments can be made to eliminate the material effects of such differences.

In order to apply the RPM there is a need for clear Transactional comparables. In case only accounting based data is available this will not be considered sufficient to use the RPM, as differences in factors such as accounting treatments make it difficult to arrive at an accurate comparable.

In making comparisons for purposes of the RPM, fewer adjustments are normally needed to account for product differences than under the CUP, because minor product differences are less likely to have as material an effect on profit margins as they do on price. This is mainly related to the fact that gross margin represents the gross compensation received by the reseller and thereby this method focusses more on the remuneration received for the functions performed (taking into account assets used and risks assumed).



**Best use
scenario and
adjustments
to be
considered**

4.2.3. Cost Plus Method

4.2.3.1. Definition



Definition

The Cost Plus Method as described in this Guideline determines an Arm's Length Price by adding an appropriate mark-up to the costs.

4.2.1.2. Explanation and numerical example



Explanation and numerical example

The Cost Plus Method ("C+ Method") begins with the costs incurred by the supplier of property (or services) in a Controlled Transaction for property transferred or services provided to a related purchaser. An appropriate cost plus markup (being a gross margin) is then added to this cost, to make an appropriate profit in light of the functions performed and the market conditions. The amount arrived at after adding the cost plus markup to the above costs may be regarded as an Arm's Length Price of the original Controlled Transaction. Thus, the C+ Method determines an Arm's Length Price by adding an appropriate mark-up to the costs.

Appendix 4 includes an example of the C+ Method.

4.2.1.3. Best use scenario and adjustments to be considered

The C+ Method is most useful when semi-finished goods are sold between Related Persons, when Related Persons have concluded joint facility agreements or long-term buy-and-supply arrangements, or when the Controlled Transaction is the provision of services.

As with the RPM, the C+ Method could use both internal as well as external comparables. The internal comparable is the cost plus mark-up that the controlled supplier earns in comparable Uncontrolled Transactions. The external comparable is the cost plus mark-up that would have been earned in Comparable Transactions by an Independent Person.

In order to apply the C+ Method there is a need for clear transactional comparables. In case only accounting based data is available this will not be considered sufficient as differences in e.g. accounting treatments make it difficult to arrive at an accurate comparable.



**Best use
scenario and
adjustments
to be
considered**

As with the RPM fewer adjustments may be necessary to account for product differences under the C+ Method than the CUP, and it may be appropriate to give more weight to other comparability factors such as functions performed, risks assumed, and assets employed. When there are differences that materially affect the Cost Plus mark-ups earned in the Controlled and Uncontrolled Transactions, reasonably accurate adjustments should be made to account for such differences. The extent and reliability of those adjustments will affect the relative reliability of the analysis under the C+ Method in particular cases. A key factor in applying and determining the reliability of the C+ Method is the determination of costs. The various methods for determining costs should be consistent between the Controlled and Uncontrolled Transactions and consistent over time in relation to particular Persons.

4.2.4. Transactional Net Margin Method

4.2.4.1. Definition



Definition

The Transactional Net Margin Method (TNMM) compares the net profit level between the Controlled Transactions and Uncontrolled Transactions. As such, the TNMM examines the net profit relative to an appropriate net margin indicator.

4.2.4.2. Explanation and numerical example

The TNMM operates in a manner similar to the C+ Method /RPM and, therefore, must be applied in a manner consistent with the manner in which the C+ Method or RPM is applied. In order to apply the TNMM a profit level indicator ("PLI") should be selected to determine the appropriate net margin indicator for the Controlled Transaction(s). There are different PLIs that may be considered appropriate (the list below is non-exhaustive):

- Operating Profit Margin ("OPM") or Return On Sales ("ROS");
- Net Cost-Plus ("NCP") or Full cost markup ("FCM");
- Return on (operating) Assets ("ROA") or return of capital employed ("RoCE")
- Berry Ratios (ratios of gross profit divided by operating expenses)



Explanation and numerical example

More details on these methods and when these PLIs may be considered most useful is included in the Paragraph(s) below.

This means that a TNMM analysis can be based on the net profit indicator that the same Taxpayer earns in comparable Uncontrolled Transactions. This could be analyzed by making reference to "internal comparables," or when this is not possible, the TNMM can be based on the net margin indicator earned in Comparable Transactions by an Independent Person ("external comparables").

A Functional Analysis of the Controlled and Uncontrolled Transactions is required to determine whether the Transactions are comparable and what, if any, adjustments may be necessary to obtain reliable results.

See Appendix 5 for an example of TNMM.

4.2.4.3. Best use scenario and adjustments to be considered

The TNMM is unlikely to be reliable if each Person to a Transaction makes unique and valuable contributions. In these cases, the PSM will generally be the more appropriate method. However, the TNMM may be applicable when one of the Related Persons makes all the unique and valuable contributions involved in the Controlled Transaction, while the other Person makes no unique and valuable contribution (such as using goods that are not unique, or providing services such as routine distribution).

The Related Person to the Controlled Transaction to which the TNMM is applied should be the Person for whom reliable data on the most comparable Uncontrolled Transactions can be found. In general, this means that the so-called "Tested Party" is the least complex party of the Related Persons in the Controlled Transaction, that does not own valuable Intangible property or unique assets (further explained in 4.3.1 below).



**Best use
scenario and
adjustments
to be
considered**

In applying the TNMM, it is important to determine the relevant profits from the Controlled Transaction and Uncontrolled Transactions and to pick the correct net margin indicator to use in analyzing those Transactions. In the selection of the most appropriate net margin indicator, the respective strengths and weaknesses of the various possible indicators should be considered.

These include:

1. The appropriateness of the indicator considered in view of the nature of the Controlled Transaction, determined in particular through a Functional Analysis;
2. The availability of reliable information (in particular on Uncontrolled comparables) needed to apply the TNMM based on that indicator; and
3. The degree of comparability between Controlled and Uncontrolled Transactions, including the reliability of comparability adjustments that may be needed to eliminate differences between them when applying the TNMM based on that indicator.

The denominator of the net margin indicator (i.e. PLI) should reflect the relevant indicators of value of the functions performed by the Tested Party in the Transaction under review, taking into account its risks assumed and asset employed. The denominator should in general be based on an uncontrolled base. For instance, the denominator to determine the value of a distribution function is generally based on external revenues (i.e. based on Uncontrolled Transactions), as these are not controlled or directly influenced by the Related Person(s) or Controlled Transaction(s).

The denominator for PLIs include:

- OPM/ROS: the margin calculated by dividing earnings before interest and tax (“EBIT”) or operating profit by net sales.



**Best use
scenario and
adjustments
to be
considered**

OPM/ROS is a way to measure profitability for companies and industries of differing sizes. It does not account for capital investment used to generate a profit. The use of operating profit as a measure of cash flow reduces the effect of accounting, financing and tax policies on profits. This method may be most appropriate when applied to marketing and distribution activities.

- NCP/FCM: EBIT or operating profit divided by total costs.

The NCP / FCM is a measure of return on costs using the total operational cost of the Person (excluding interest payments and tax expense). The ratio can allow for differences in functions by assuming that they are reflected in the level of selling, general and administrative (SG&A) expenses, with many items able to be included in either cost of goods sold or operating expenses. Typically, the net cost plus margin is appropriate for manufacturing operations or a service providing entity, since the activities it performs in providing the service are reflected in its costs. The Tested Party usually has direct control of the per unit expenses, volume produced, labor and operating expenses.

- RoA/RoCE; operating profit divided by operating assets.

The RoA ratio is similar to return on assets, but takes into account sources of financing. The denominator uses operating assets, also called capital employed, instead of total assets. Operating assets are calculated using total assets less current liabilities or fixed assets plus working capital. This ratio generally considers the amount of capital needed for a business to function. This ratio may be useful when used to determine a transfer price where there are capital intensive activities or where considerable capital is at risk in the Transaction(s). The Tested Party would be directly responsible for managing the risks related to the capital and the capital is significant to the Transaction(s).

- Berry ratios (i.e. ratios of gross profit to operating expenses).



**Best use
scenario and
adjustments to
be considered**

The Berry Ratio may be appropriate when the Tested Party is a distributor or service provider. The Berry Ratio assumes that there is a relationship between the level of operating expenses and the level of gross profits earned by distributors and service providers (on the assumption that the value-added functions are captured in the operating expenses).

It may be appropriate to use the Berry Ratio if the selling or marketing Person is a distributor and is entitled to a return on its operating expenses alone or if it is a service provider entitled to a return on its costs of provision of its services alone, because such assumption is more reliable for the distributors and service providers than manufacturers. The Berry Ratio may be applied specifically in cases for intermediary activities where a Taxpayer purchases goods from a Related Person and on-sells them.

There may be other net profit indicators appropriate depending on the facts and circumstances of the Transactions also considering the industry in which the MNE operates. Particularly, where data on Uncontrolled Transactions is available, the following other denominators could be considered and further analyzed such as, number of employees, floor area of retail points or weight of products transported.

4.2.5. Profit Split Method

4.2.5.1. Definition



Definition

The PSM identifies the combined profit for the Related Persons from a Controlled Transaction or Transactions. Thereafter, the PSM splits those profits between the Related Persons on an economically valid basis. The resulting split should approximate the division of profits that would have been anticipated and reflected in an agreement made at Arm's Length between Independent Persons.

4.2.5.2. Explanation and numerical example



Explanation and numerical example

There are two approaches most commonly taken to divide the combined profits:

1. Contribution analysis; and
2. Residual analysis.

The contribution analysis divides profits on the basis of the relative contribution of the Persons. In this respect, contributions are determined based on the relative value of each function performed, assets used, and risks assumed by each of the Related Persons to the Controlled Transaction. Further, the division of profits could be supported by external market data that reveal how Independent Persons would have divided the profits under similar circumstances.

The residual analysis is a two-step process.

- In the first step, each Related Person that contributes non-unique elements should receive a routine return. This return for non-unique elements would in general be tested based on a TNMM or other Method.
- In the second step, the remaining profits are split using a contribution analysis or other allocation approaches based on the underlying facts and circumstances of the Controlled Transaction.

Appendix 6 includes an example of the PSM.

4.2.4.3. Best use scenario and adjustments to be considered

The following three factors indicates that the transactional PSM may be the most appropriate method:

1. Whether each Person is making unique and valuable contributions;
2. Whether the business operations of the Persons are so highly integrated that the Persons' contributions cannot be reliably evaluated in isolation from each other; and
3. Whether the Persons share the assumption of economically significant risks or separately assume closely related risks.

The term "unique and valuable contributions" includes functions performed and assets used or contributed in cases in which they are not comparable to contributions made by Independent Persons in comparable situations and they are key source of economic benefits in the business operations. The existence of unique and valuable contributions is perhaps the clearest indicator that a PSM may be appropriate.



**Best use
scenario and
adjustments
to be
considered**

The criteria or allocation keys that could be used to split the profit should be verifiable and based on internal accounting data or on measurable market data, if available. In practice, various internal data such as assets, costs, and headcount may be used as allocation keys to split the profit. For self-developed assets, which may not be on the balance sheet, valuation techniques such as discounted cash flow may be used. If more than one allocation key is used to split the profit between the Related Persons, it is necessary to determine the relative contribution of each allocation key in earning the combined profits.

The measure of profits to be split will depend on the risks the Persons share. In many cases, operating profit may be the most appropriate measure of profits to split because the Persons share in the risks of the entire business. However, if the Persons share only the risks associated with the volume of sales and production of the products, and they do not share the risks associated with selling the products in the marketplace, then a split of gross profit may be appropriate.

Guidance is provided on when it is appropriate to split actual or anticipated profits:

- The splitting of actual profits is appropriate when all the relevant Persons share the assumption of the same economically significant risks or separately assume closely related, economically significant risks. This kind of risk assumption may arise if the business operations are highly integrated and / or each Person makes unique and valuable contributions.
- A split of anticipated profits, in contrast, would be more appropriate if one of the Persons does not share in the assumption of all of the economically significant risks, which might exist after entering into the Transaction.



**Best use
scenario and
adjustments to
be considered**

Whether actual or anticipated profits are split, the basis for splitting profits must be determined on the basis of the information known or reasonably should have been known at the time the Related Persons entered into the transaction.

The weaknesses of the profit split method are the difficulty with accessing the relevant information that is required to apply the PSM reliably. Generally, there is no easily accessible third party data available on what profit split Independent Persons would agree upon under comparable facts and circumstances. Besides, issues may arise in measuring all the relevant financial figures (e.g. costs and revenue base) which are used for the actual application of the PSM. Finally, the splitting factors which could be applied are in principle subject to the judgement of both the Taxpayer as well as tax administration. The preparation of proper documentation by Taxpayers explaining all relevant information used for the application of the PSM is therefore crucial.

4.2.6. Other considerations

If the Transfer Price between Related Persons deviates from the price that would have been agreed upon by Independent Persons, this does not give rise to an automatic determination that Related Persons are manipulating their profits. For example, there might be difficulty in determining the market price in the absence of market forces that would have an effect on Independent Persons or a particular commercial strategy that Related Persons adopted (e.g. market penetration or start up strategy). It should be determined on a case-by-case basis whether the Transfer Prices between the Related Persons could be in accordance with the Arm's Length Principle.

4.3. Step 3: Selection of comparables

The third and final step in the comparability analysis is the selection of comparables. For the selection of comparables there are various practical aspects that should be considered when applying the above outlined Transfer Pricing Methods as approved by the TP Bylaws. These practical aspects are especially relevant for the Transfer Pricing Methods that use third party data to make an assessment of the Arm's Length Nature of the Controlled Transaction. As such, this Paragraph will cover some practical Guidance for the following Methods:

RPM (external)

C+ Method (external)

TNMM

For these three approaches, certain margins achieved by comparable Independent Persons are used as a reference point to the Arm's Length Nature of the Controlled Transactions. The premise is that if Independent Persons report a certain margin on a (set of) Transaction(s), this could be considered at Arm's Length when also achieved by the Related Person. The following sub steps should be applied when applying these methods:

-
- 1 Selection of Tested Party
 - 2 Selection of appropriate database
 - 3 Selection of appropriate search criteria and year(s) to be covered
 - 4 Selection of sufficiently comparable Person
 - 5 Selection of a relevant profit level indicator
 - 6 Determination of arm's length range of comparable margins
-

4.3.1. Sub-step 1: Selection of Tested Party

As a first step, the Tested Party should be selected. The Tested Party will be the Related Person that will be assessed when applying the selected Method. In this respect, the margins reported by the Tested Party will be checked against the Arm's Length Range that is derived from the analysis. In general, the Tested Party is usually the least complex party to the Transaction, as this allows for easier comparison of the margin as opposed to a more complex party. This should be determined during the Functional Analysis as outlined in Paragraph 4.1.2.1. whereby in most circumstances the least complex party performs relatively limited functions, bears relatively limited risks and owns no significant or only relatively routine assets in the course of its activities.

4.3.2. Sub-step 2: Selection of appropriate database

In order to properly perform the analysis, an appropriate database should be used. There are many databases containing information about parties to Transactions, including profit and loss statements, balance sheets and general information on the activities employed by the Person. Depending on the Tested Party, an appropriate database should be used in gathering the necessary information. No specific database is prescribed in the TP Bylaws, and the Authority will not automatically reject the use of any particular database provided that the information derived from that database is accessible to it. However, Taxpayers are required to substantiate the appropriateness of using a certain database in the analysis. When selecting an appropriate database and applying search criteria (e.g. selection of region), the Taxpayer must substantiate why the database as well as the criteria used with respect to the search performed are considered appropriate.

In almost all cases, for obtaining the financial information of comparable Uncontrolled Transactions or data of Persons, public databases and other available information sources may be used. For more information, reference is made to Article 13 of the TP Bylaws.

Notwithstanding the foregoing, the use of undisclosed "secret" comparables (i.e. data which is not publicly or commercially available, comparables that are not available in the appropriate database(s), or those not available in publicly available data) is not permissible and will be rejected. As such, comparability analyses may not be based on undisclosed "secret" comparables and may not rely upon such data in any way.

4.3.3. Sub-step 3: Search criteria and year(s) to be covered

In the selection of comparables, it is important to know the year or years covered by the analysis. The year in which the date of a Controlled Transaction - the prices of which will be tested to determine if they are at Arm's Length - must be covered by the analysis.

When performing the analysis using an appropriate database, a set of potentially comparable Persons needs to be formed. Most databases contain data of millions of companies, requiring specific criteria to limit the set of potentially comparable Persons in order to find a set that can be considered comparable with the Tested Party in terms of functional profile and industry. In this respect, the use of appropriate search criteria for the comparables is expected, and the Taxpayer must be able to demonstrate the appropriateness of the criteria.

For determining the Arm's Length Range of the Transaction, in certain cases it might be useful to use multiple-year data if they add value to the Transfer Pricing analysis. To obtain a complete understanding of the facts and circumstances of the Controlled Transaction, generally it might be useful to examine data from the year in which the date of Controlled Transaction under examination falls and prior years. For example, the use of data from the most recent years available will show whether a Taxpayer's reported loss on a Transaction is part of a history of losses on similar Transactions, the result of particular economic conditions in a prior year that increased costs in the subsequent year, or a reflection of the fact that a product may be at the end of its life cycle. Multiple-year data will also be useful in providing information about the relevant business and product life cycles of the comparables.

As such, in order to normalize the data of potentially comparable Persons, searches should include three (3) consecutive years of data. In that case, the Arm's Length Range is to be calculated using the weighted average of these three years from which the data is derived. The Authority also expects that comparable Persons do not report any losses in the years under review. Other search criteria should be aligned with the Tested Party, whereby each step should be substantiated with the purpose of finding a comparable set of Persons.

4.3.4. Sub step 4: Selection of comparables

Following the above search criteria, each potentially comparable Person resulting from the database search should be assessed to determine its comparability to the Tested Party. In this respect, the Authority expects that each comparable is reviewed to assess comparability to functions being performed, risk profile, industry and any other applicable comparability factor relevant for the situation. It is not sufficient to accept Persons for comparability purposes without doing some review as to whether the set of comparable Persons are reasonably comparable to the Related Persons under analysis. A “data-dump” of database information without review is not considered sufficient substantiation for the Arm’s Length Nature of the Controlled Transactions.

Furthermore, to prevent exceptional companies and circumstances having a significant impact on the Arm’s Length Margin that is reported by the comparable Persons, it is expected to obtain a set of comparables to perform a relevant statistical analyses (see sub step 6 below).

As part of the selection of comparables the Authority does not accept loss making entities as comparable Persons.

Finally, comparability adjustments to the financials of the comparables are solely allowed if they can be made with a high degree of accuracy and if the impact on the comparables is not material. Such adjustments should serve to improve the outcome of the analysis and eliminate potential smaller differences between the comparables. All comparability adjustments need to be properly substantiated by Taxpayers.

4.3.5. Sub step 5: Selection of profit level indicator

Once a list of identified comparable Persons is compiled, an assessment of the most appropriate PLI should be made. This PLI should be aligned with the Tested Party in that it best demonstrates an Arm's Length Return following the functional profile. As mentioned earlier, example of PLIs can be (non-exhaustive list):

- Gross or net margin compared to costs;
- Gross or net margin compared to revenue; or
- Gross or net margin compared to assets.

Taxpayers are expected to substantiate the application of the PLI.

4.3.6. Sub step 6: Determination of Arm's Length Range

Finally, the Arm's Length Margin can be calculated. In some cases, the application of the Arm's Length Principle will produce a single reliable Arm's Length outcome. However, there may also be many occasions when the application of one or more of the most appropriate Transfer Pricing Methods produces a range of figures that are relatively equally reliable. In such cases, a substantial deviation among points in the range could indicate that the data used to establish some of the points in the range might not be as reliable as the data used to establish the other points in the range, or that the deviation may result from features of the comparable data that require adjustments. Accordingly, further analysis of those points may be necessary to evaluate their suitability for inclusion in the Arm's Length Range.

To prevent the impact of outliers and exceptional circumstances, a statistical approach to the Arm's Length Range is required. In this respect the interquartile range is considered an appropriate approach to determine an Arm's Length Range of margins.

Generally, any point within this interquartile range should be considered in line with the arm's length principle. However, unless properly substantiated otherwise, the Authority expects that the median point is used when determining the Transfer Pricing Policy if the prices are outside the interquartile range.

4.4. Financial analysis

4.4.1. Arm's Length Range

Part of the Transfer Pricing analysis is the testing of implementation of the Transfer Pricing Policy within the Group. Taxpayers are expected to test the Arm's Length Nature of the Transfer Pricing policy and the adequate implementation thereof on a continuing basis. Adjustments to the Controlled Transactions may be made from time to time to ensure an Arm's Length result over the financial year. Nevertheless, there may be good reasons that the result of the tested Transaction is not within the Arm's Length Range. However, such Person should be able to substantiate such reasons.

For Transfer Pricing Methods that use an Arm's Length Margin as reference point, special consideration should be given to the applicable revenues and expenses that are used in determining if the actual results are consistent with the Arm's Length Pricing.

In some cases, there might be a shift within the Range as a result of a subsequent downward or upward adjustment to the Arm's Length Price originally determined. Taxpayers must be able to substantiate the changed circumstances that would justify an adjustment of the Controlled Transaction accordingly. For instance, an adjustment could be justified if the terms for the changed pricing is explicit in the Controlled Transaction agreements concluded between the Related Persons, and that the adjustment is actually charged to the Related Person part of the Controlled Transaction.

If no changed circumstances can be identified that justify an adjustment of the Controlled Transaction, it will be assumed that the adjustment is most likely for tax reasons. Under these circumstances an adjustment of the Controlled Transaction may be disregarded by the Authority.

Following the above, it is expected that the Controlled Transaction is continuously monitored to ensure an Arm's Length outcome. If due to unforeseen circumstances the actual result reported falls outside the Arm's Length Range, Taxpayers can make a so-called year-end adjustment provided that the annual accounts have not yet been finalized.

The Authority expects Taxpayers to adjust the Arm's Length results to the median value of the Arm's Length Range should the actual result be less than the lower quartile of the Arm's Length Range. In exceptional situations (demonstrated and substantiated by a Taxpayer), a deviation of the median of the Arm's Length Range might be acceptable if justified. Any result above the upper quartile of the Arm's Length Range might be adjusted to a point within the Range, but not lower than the median value.

4.4.2. Portfolio approach

In principle each Transaction should be assessed in isolation. In specific circumstances a portfolio approach could be used (i.e. a bundling of multiple Transactions for the purpose of earning an appropriate return on the portfolio instead of on a specific product or service). The portfolio approach may only be considered if the same Person(s) participate in all the bundled Transactions and, as a result, all bundled Transactions are reported by the same Person.

For example,

Example

a Taxpayer has two Transactions. Transaction 1 is the sale of product A to counterparty 1, which is marketed with a low margin or even a loss (i.e. it does not satisfy the arm's length principle on an isolated basis). Transaction 2 is the sale of product B to counterparty 1, which is not priced with a low margin. The demand for product B is triggered by the sale of product A. In this example, the counterparty is the same, and on a combined basis the profit margin in relation to the sale of product A and product B (i.e. the portfolio) satisfies the Arm's Length Principle.

4.4.3. Losses

If a Related Person consistently reports losses whilst the MNE Group as a whole is profitable, the facts and circumstances could trigger specific focus from a Transfer Pricing point of view and may result in further examination by the Authority. Whilst Related Persons, like Independent Persons, may sustain genuine losses (in line with their functions performed, assets used, and risks assumed), it is not reasonable to tolerate losses indefinitely. Recurring losses for a reasonable period may be justified in some cases by a business strategy to set especially low prices to achieve market penetration. However, low prices/margins should be expected for a limited period only, with the objective to improve profits in the longer term.

In principle, each individual financial year should reflect an Arm's Length outcome (i.e. report results within the Arm's Length Range). Notwithstanding the above and aforementioned, in cases where a Taxpayer that is considered a limited risk entity reports a loss that can no longer be adjusted by above mentioned means, in exceptional cases and depending on the situation, a multiple year approach could be applied to ensure an overall Arm's Length outcome.

Example

the Taxpayer reports a loss in year 1. It should be determined if this is an exceptional case and what the circumstances are that resulted in the loss situation. If the situation is an exception and in other years all factors that impact the profit and loss statement are constant, it may be considered to use a multiple year approach (e.g. combining year 1 and year 2) to determine the overall Arm's Length nature of the multi-year outcome. Based on proper substantiation of the exceptional nature of the case, an average multi-year Arm's Length outcome may be accepted by the Authority for Transfer Pricing purposes.

4.4.4. Frequency of updating Arm's Length testing/determining Arm's Length Range

Furthermore, in general the analysis to determine the Arm's Length Range should, be fully updated every 3 years. In case of a change in circumstances it may be required to update the full analysis (i.e. the 6 sub steps as referred to above) or, depending on the circumstances, require an update of the benchmark performed, at an earlier point in time.

5.

Transfer Pricing Documentation

5. Transfer Pricing Documentation

This Chapter includes additional guidance on the Transfer Pricing documentation requirements in KSA.

- In general there are four TP documentation requirements: (i) the General documentation, (ii) the Master File, (iii) the Local File and (iv) the Country-by-Country Report.
- The documentation requirements imposed by the KSA includes the preparation of a Master File and a Local File for Taxpayers that meet the given threshold. As such, the following are exempt from these additional documentation requirements: (i) Natural Persons, and (ii) Small Enterprises.

5.1. Basic premise

This Paragraph provides additional guidance on the domestic Transfer Pricing documentation requirements of the KSA. In the previous section, additional Guidance and information was provided on how the Arm's Length Principle could be satisfied for Controlled Transactions within MNEs. Next to this, Taxpayers are required to have Transfer Pricing documentation available to support that the Controlled Transactions between Related Persons satisfy the Arm's Length Principle.

As outlined in Chapter 8 of the TP Bylaws, the KSA has the following Transfer Pricing documentation requirements:



General documentation

General documentation should be available in respect of Taxable Persons who are a party to a Controlled Transaction within the same Tax Jurisdiction as well as cross-border Controlled Transactions.

Master File

Master File provides an overview of the MNE's global business, the Transfer Pricing Policy and economic activities/functions of the Related Persons.

Local File

Local File provides detailed information on Controlled Transaction with the Taxable Person and is, accordingly, supplementary to the Master File.

Country-by-Country report

Country-by-Country report includes Tax Jurisdiction-wide information on various information relating to the MNE's global activities.

Taxpayers are obliged to prepare the Transfer Pricing documentation if the Statutory Thresholds indicated in the TP Bylaws are met²².

One of the objectives is to ensure that Taxpayers have properly considered the Transfer Pricing position taken and have also sufficiently documented these considerations. The compliance requirements could help to ensure this, since Taxpayers would have to analyse the positions taken and Transfer Pricing Policies in place, as ultimately reported in tax returns.

From the perspective of The Authority, effective Transfer Pricing risk assessments can be conducted since Taxpayers provide valuable and reliable information to the tax authorities in an early stage. Thus, these Transfer Pricing documentation requirements are intended to provide sufficient and reliable information to perform a high quality Transfer Pricing risk assessment.

Additionally, Transfer Pricing documentation prepared by Taxpayers provides useful information when dealing with the Authority during a tax audit on the Transfer Pricing position taken. The information provided in the Transfer Pricing documentation is, however, not always sufficient to conduct a tax audit and under these circumstances the Authority may require additional information to support the Transfer Pricing position taken. When documents and other information important for a tax audit are held by Related Persons to the Taxpayers in foreign countries, the Authority might be able to obtain this information through international information sharing (agreements). The Authority will initially ask the Taxpayer whether or not the information for a tax audit can be provided. If the Taxpayer cannot or does not provide the requested information the Authority might consider seeking this information through information sharing provided, without prejudice to the Taxpayer's legal obligations to provide such documentation and any punitive measures that could be taken against the Taxpayer for failure to satisfy such obligations.

(22) Article 18 & 19 , Transfer Pricing Bylaws.

5.2. General documentation

As outlined in Article 15 of the TP Bylaws, Taxable Persons that are part of a Controlled Transactions are obliged to keep Transfer Pricing documentation to confirm that the conditions of these Transactions are at Arm's Length.

The Controlled Transactions could occur either between a Taxable Person and Related Person(s) in the KSA or with Related Person(s) established in a foreign Tax Jurisdiction. The general documentation should provide certain information available regarding the Controlled Transactions, the relationship between the Related Persons involved in the Controlled Transactions, and how the price of the Controlled Transaction(s) is calculated.

Based on the general information The Authority should be able to determine whether the Controlled Transaction is carried out on Arm's Length terms and conditions based on the documentation. With respect to general documentation, the Authority does not identify specific documentation to be maintained and therefore applies a format-free approach.

Nevertheless, it is necessary to include sufficient information to support the Arm's Length nature of the Controlled Transactions. Although no specific requirements are prescribed, generally most information listed in the Bylaws under the Master File and Local File should be documented, including in particular a Functional Analysis and an economic analysis.

In general, the documentation must be provided by the Taxpayers to the Authority upon request within the time period specified by the Authority in the request which will in all cases be no less than 30 days.

5.3. Master File and Local File

The documentation requirements imposed by the KSA includes the preparation of a Master File and a Local File for Taxpayers that meet the given threshold. As such, the following are exempt from these additional documentation requirements:

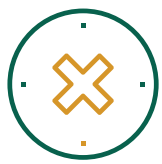

Natural
persons

Small
Enterprises

a juridical person who carries out Controlled Transactions, for which the total Arm's Length value does not exceed six-million Saudi Riyals (SAR 6,000,000) in a 12 month period.

Notwithstanding the provisions of the preceding paragraph, the Authority may direct any Person to prepare and maintain documentation related to Controlled Transactions and to request such Person to provide such documentation within the time specified in the request, which -in all cases- shall be no less than thirty (30) days from the date of the Authority's request in any of the following cases:

1. Where Controlled Transactions are performed with Persons deemed to be residents of, or established in a special economic zones situated in the Kingdom;
2. Where Controlled Transactions are carried out with Persons who are legally granted any exemption or relief from tax or zakat obligations, or both, in the Kingdom;
3. Where the Authority has reason to believe that any of circumstances covered under Article 63 (1) of the Law exists;
4. Where the Person has submitted a request for a corresponding adjustment in accordance with Chapter 9 of the Bylaws; or
5. Where the provision of the requested document(s) is necessary for the authority to obtain for purposes of fulfilling of the obligations of the Kingdom under an International Agreement to which the Kingdom is a party.

Persons that are not exempt must maintain a Master File and a Local File that meets minimum content requirements. For avoidance of doubt, a Taxpayer that is exempt from the Master File and Local File should maintain the general documentation as described in Paragraph 5.2

5.3.1. Master File

The Master File is intended to give an overview of the MNE's global business operations, its Transfer Pricing Policies applied within the group and the economic activity of the Related Persons in the MNE. In general, this information is provided for the whole group but under specific circumstances the Master File might be separated into separate parts (for example in case where a specific line of business operates independently it might improve readability to separate this). This does not eliminate the fact that the Master File including all business lines should be available for the KSA upon request²³.

The minimum content to be included in the Master File is highlighted in Appendix 8.

5.3.2. Local File

Contrary to the Master File, the Local File must contain more detailed information about the Taxpayers. The Local File supplements the Master File by detailing the conditions and circumstances of the Taxpayer and its Transactions, including the Transfer Pricing positions taken by the Taxpayer and an assessment of whether the Taxpayer's Controlled Transactions are consistent with the Arm's Length Principle²⁴.

The required content of the Local File includes a detailed Functional Analysis providing an overview of the functions performed, risk assumed, and assets used related to the Controlled Transaction, relevant financial information on the Controlled Transaction, a comparability analysis and the selection and application of the most appropriate Transfer Pricing method²⁵. A Local File should in principle be prepared by each Taxpayer.

However, from a practical point of view, it might be acceptable to prepare one combined Local File for multiple Taxpayers who belong to the same MNE Group if the combined Local File includes a similar level of detail with respect to the individual Taxpayers as it should contain in the separate and individual Local Files of each Taxpayer.

Please review Appendix 9 for information regarding the minimum content that must be included in the Local File.

(23) Article 16, Transfer Pricing Bylaws.

(24) Article 17, Transfer Pricing Bylaws.

(25) Article 17, Transfer Pricing Bylaws.

5.4. Country-by-Country reporting

5.4.1. General introduction

Through the Country-by-Country Report (CbCR), insight is provided with respect to the MNE Group's aggregate multi-jurisdictional tax information on the global allocation of income, taxes paid and an indication where the economic activity within the MNE takes place. The Authority requires Taxpayers to provide, on an annual basis, detailed information about various aspects of its MNE Group's business in each Tax Jurisdiction where the Group operates, including aspects such as profit (or loss) before tax, income tax paid, number of employees and tangible assets. A CbCR must contain:



CbCR Content

- Information relating to the aggregate value of revenue (both from Controlled and Uncontrolled Transactions), profit (or loss) before income tax, income tax paid, income tax accrued, stated capital, accumulated earnings, number of employees, and tangible assets other than cash or cash equivalents in respect of each country in which the MNE Group of the Taxable Person operates; and
- An identification of each Constituent Entity of the MNE Group indicating the country of tax residence of each Constituent Entity, where different from the country of tax residence, the country under the laws of which the Constituent Entity is organized and the nature of the main business activity or activities of such member entity.

In principle, the CbCR should be submitted by the Ultimate Parent Entity or Surrogate Parent Entity²⁶. Thus, if the Taxpayer²⁷ in KSA is either the UPE or SPE, that Taxpayer must submit a CbC Report to GAZT within the 12-month period immediately following the end of the Reporting Year of its MNE Group. However, according to the Bylaws, filing a CbC Report is not required in KSA if the consolidated Group revenue is less than Three Billion & Two Hundred Million Saudi Riyals (SAR 3.2 Billion) in the Reporting Year immediately preceding the current Reporting Year²⁸.

(26) Article 18(A), Transfer Pricing Bylaws.

(27) In this context, Taxpayer includes Persons subject to income tax in the Kingdom, Persons subject to Zakat in the Kingdom or both (such as Mixed Companies).

(28) Article 18(G), Transfer Pricing Bylaws.

Example:

Company X is a company fully owned by Company G, a company residing in country Y and the UPE of the MNE Group that operates in over 100 countries. Company X is an LLC established under the laws and regulations of the Kingdom and is a KSA resident for tax purposes. Company X's Reporting Year coincides with the Reporting Year of the MNE Group Company G, which is the calendar year ending on 31 December. Company X submits its annual income tax returns to GAZT on the 1st of April, 2021. The Reporting Year in this case is 2020. According to the tax laws of Country Y, a UPE of an MNE Group is not required to submit a CbCR if the Group's consolidated revenue is less than 2 Billion US Dollars (USD 2bn) (equivalent of SAR 7.5 bn) for the year preceding the current tax year. Thus, in 2021, Company G is not required to file a CbCR in Country Y.

The 2019 year-end Consolidated Financial Statements of the Company G reports USD 1.2 Billion in revenue (SAR 4.5 Billion). According to the Bylaws, the MNE Group is required to submit a CbCR since its group revenue in 2019 (the year preceding the Reporting Year) exceeded the Consolidated Revenue Statutory Threshold ("CRST"), and Company X must submit the CbCR Notification to GAZT as per Article 18(F) of the Bylaws within 120 days after 31 December, 2020. Since Company X submitted its tax return on April 1, 2021, the CbCR Notification was submitted to GAZT as part of the tax return. Company X must file the CbCR to GAZT within the 12-month period following December 31, 2020 (i.e. no later than December 31, 2021).

In some cases, a Constituent Entity of the MNE Group other than the UPE and SPE may be required to file the CbC Report in KSA. Provided the SCRT in the Bylaws is met, a Taxable Person who is a Constituent Entity of the MNE Group will be obligated to submit a CbC Report to GAZT within the 12-month period immediately following the end of the Reporting Year in any of the following cases:



Cases

1. the Ultimate Parent Entity or Surrogate Parent Entity of the MNE Group is not obligated to file a CbC Report in its Tax Jurisdiction in which it is a tax resident;
2. the jurisdiction in which the Ultimate Parent Entity or in which the Surrogate Parent Entity is a tax resident is party to an International Agreement that is valid and enforceable during the statutory period for the submission of the CbC Report²⁹, but is not a party to Qualifying Competent Authority Agreement that is enforceable at that time; or
3. the jurisdiction in which the Ultimate Parent Entity or in which the Surrogate Parent Entity is a tax resident Systemically Fails to automatically provide the Kingdom with CbC Reports related to the activities of the MNE Groups that have Constituent Entities in the Kingdom.

Further information is provided in Chapter 6 of this Guideline.

(29) Article 18(D), Transfer Pricing Bylaws.

5.4.2. Practical Guidance on CbCR

Appendix 10 includes a sample of the three tables that are part of the Model Template for CbCR. If a Person located in the KSA meets the threshold to file the CbCR, the templates of the report should be filled in with the specific information of the MNE Group. Below some additional guidance relating to the CbCR is included (any references to the table or columns of a table relate to the CbCR template as included in Appendix 10).



Explanation

Period covered

Provided the CSRT is met annually and that the Taxpayer is required to file a CbCR to GAZT, the CbCR should be submitted on an annual basis covering the Reporting Year of the MNE Group. The Reporting Year must be determined pursuant to the Income Tax Law and its Implementing Regulations. Generally, each submitted CbCR should cover information pertaining to the Reporting Year of the MNE Group. It is important that CbCR data is provided in a consistent manner. Accordingly:

1. A CbCR must be submitted on an annual basis by the appropriate Reporting Entity containing information relating to the fiscal year of each Constituent Entity of the MNE Group ending on the same date as the fiscal year of the MNE Group of which they are constituents, or ending within the 12-month period immediately preceding the last day of the MNE Group's fiscal year; or
2. information relating to all relevant Constituent Entities with respect to the fiscal year of the Reporting MNE.

Source of data



Explanation

A Reporting MNE is required to use the same sources of data from year-to-year co when completing the CbCR. The Reporting MNE may choose to obtain data from:

- Consolidation reporting packages;
- Separate entity statutory financial statements;
- Regulatory financial statements; or
- Internal management accounts.

It is not required to reconcile the revenue, profit and tax reported in the template to the consolidated financial statements. Further, in case the separate Constituent Entities' statutory financial statements are used as a basis for the preparation of the CbCR, all amounts should be converted to the functional currency of the reporting MNE at the average FX rate for the year covered by the Report. The average FX rate used must be included in the additional information section of the Model Template.

The reporting MNE is required to provide a brief description of the sources of data used in preparing the template, more specifically this should be included in the additional information section of the CbCR template. there is change in the data-source is used for the preparation of the report, the Reporting Entity should provide reasons for this change and the impact on the various elements of the CbCR.

Treatment of Permanent Establishments for CbCR purposes

Data related to Permanent Establishments of the Constituent Entities of the MNE Group should also be included in the CbCR. In this respect, the Tax Jurisdiction of the PE is relevant and should be included and not the Tax Jurisdiction of the Person having the PE. The financial data related of the PE should be included separately from the Person having a PE.



Instructions Process

Considerations for table 1: overview of allocation of income, taxes and business activities by Tax Jurisdiction.

- Field (1) should include the Name of the MNE Group, the Reporting Year for which the CbCR relates and the MNE Group's Functional Currency.
- Field (2) should include the Tax Jurisdictions in which the Constituent Entities of the MNE Group reside for tax purposes (if different from the jurisdiction of establishment this should be indicated). If required, the applicable tie-breaker in the tax treaties should be applied to determine the Tax Jurisdiction. If no tax treaty exists, residency is determined based on the place of effective management³⁰. Furthermore, a separate line should be included for Constituent Entities that are not a tax resident in any jurisdiction.
- Field (3) should report the revenue of the Reporting MNE. Revenue should include proceeds/revenue from sales of inventory and properties, services, royalties, interest, premiums and any other amounts. However, revenue should exclude payments received from other Constituent Entities that are treated as dividends in the jurisdiction in which the Entity distributing the dividends resides. It should be reported as follows:
 - Field 3.a. revenue from Unrelated Person Transactions in the row corresponding to each Tax Jurisdiction;
 - Field 3.b. revenue from Related Person Transactions in the row corresponding to each Tax Jurisdiction;
 - Field 3.c. the total of 3.a. & 3.b.

(30) The place of effective management generally is the place where key management and commercial decisions that are necessary for the conduct of the Person's business are in substance made. The place of effective management may be the place where the most senior person or group of persons (for example the board of directors) makes its decisions, or the place where the actions to be taken by the entity as a whole are determined. However, no definitive rule may be established as all relevant facts and circumstances must be examined to determine the place of effective management on a case-by-case basis. An entity may have more than one place of management, but it can have only one place of effective management at any given time.

- In field 4, the profit or loss before income tax for all Constituent Entities should be included. The profit (or loss) before tax should also include all extraordinary income and expense items.
- Field 5 should include the total amount of income tax actually paid during the relevant fiscal year, this should include cash taxes paid by the Constituent Entity in all jurisdiction. Taxes paid should also include withholding taxes paid by any Person to all jurisdictions with respect to payments made to the Constituent Entity. For example, withholding tax is due in a foreign jurisdiction with respect to a payment made to a KSA resident Constituent Entity; the tax withheld in the foreign jurisdiction should be reported under the taxes of the KSA resident Constituent Entity Person.
- Field 6 must include the sum of accrued current tax expense on the taxable profits or losses of the Reporting Year. Only taxation from the Reporting Year covered by the CbCR should be included. Deferred tax or provision for uncertain tax liabilities should be excluded.
- Field 7 should include the sum of the stated capital for all Constituent Entities. In cases of PEs the stated capital should be included by the Constituent Entity to which the PE belongs unless there is a defined capital requirement in the Tax Jurisdiction for regulatory purposes.
- Field 8 should include the accumulated earnings for all Constituent Entities as of the end of the Reporting Year. With respect to PEs, the accumulated earnings should be reported at the level of the Person to whom the PE belongs.

- Field 9 should report the number of employees (full-time equivalent basis). The number of employees may be reported on the basis of the number of employees as of the end of the Reporting Year, or on the basis of average employment levels of the Reporting Year, or any other basis as long as the approach is consistently applied throughout all Tax Jurisdictions and Constituent Entities. Independent contractors who participate in the ordinary business activities of a Constituent Entity may be reported as employees. A reasonable rounding or approximation of the number of employees may be permissible, provided that this will not result in material deviations and that a consistent approach is being applied.
 - Field 10 should include the sum of tangible assets. The net book values of the tangible assets should be included. With respect to PEs, assets should be reported by reference to the Tax Jurisdiction in which the PE is situated. Tangible assets for this purpose does not include cash, cash equivalents, Intangibles or financial assets.
-



Instructions Process

Considerations for table 2: List of Constituent Entities of the MNE Group included in each aggregation per Tax Jurisdiction.

- Each Constituent Entity should be listed on a by Tax Jurisdiction basis and by legal entity name (must include any other identifying names used as well such as trade names). This information should include the relevant tax identification number and address -if available- for the Constituent Entity. PEs of Constituent Entities should be listed as such and by reference to the Tax Jurisdiction in which the PE is situated. The Constituent Entity to which the PE belongs must also be indicated.
- If the jurisdiction, under the laws of which a Constituent Entity is organized, incorporated or formed, is different than Tax Jurisdiction in which the Constituent Entity is a resident, the third column should list that other jurisdiction.
- The nature of the main business activities of the Constituent Entities in their respective Tax Jurisdictions should be indicated through selecting one or more of the appropriate boxes listed below:

<ul style="list-style-type: none"> o Internal Group Finance; o Regulated Financial Services; o Insurance; o Holding Shares or Other Equity Instruments; o Dormant; and/or o Other (to be specified in detail in the space provided). 	<ul style="list-style-type: none"> o Research and Development; o Holding or Managing Intellectual Property; o Purchasing or Procurement; o Manufacturing or Production; o Sales, Marketing or Distribution; o Administrative, Management or Supportive Services; o Provision of Services to Independent Persons;
--	---

Considerations for table 3: Additional information.

- Further to any of the above-mentioned elements which should be considered as part of table 3, if a Constituent Entity provides 'other' activities based on table 2 further details should be included in table three on its activities.
- Other additional information may be included by the Reporting MNE if deemed necessary or helpful.

5.5. Country-by-Country Report Notification

Every Taxpayer who is a Constituent Entity of an MNE Group must submit to the Authority a CbCR Notification no later than 120 days after the last day of the Taxpayer's Reporting Year. The CbCR Notification must include information on the identity of the Reporting Entity of the MNE Group, its Tax Jurisdiction of residence and the country in which the Reporting Entity submits the CbCR (if different). The Notification should also indicate whether the Reporting Entity is a UPE, SPE or Constituent Entity. If the Taxpayer is the Reporting Entity for the MNE Group, the Taxpayer must clarify in the CbCR Notification whether the Taxpayer is the UPE, SPE or, if neither, the reasons why it is the Reporting Entity. Finally, where due to Article 18(B) of the Bylaws, several Taxpayers belonging to the same MNE Group are required to submit a CbCR³¹, the CbCR Notification submitted by each of those Taxpayers must indicate the identity of the Reporting Entity Taxpayer selected to submit the CbCR as per Article 18(C) and other Taxpayers on whose behalf the CbCR is submitted³².

5.6. Transfer Pricing Forms

The Transfer Pricing Forms consist of the Disclosure Form of Controlled Transactions and the CbCR Notification that are part of the Tax/Zakat return. Samples of the TP Forms may be found on GAZT's website. The Disclosure Form is used by The Authority to conduct a high level Transfer Pricing Risk Assessment. Additional information supporting the Transfer Pricing position taken may be requested by The Authority.

Further information is discussed below and may be found in Appendix 11.

(31) Article 18(D), Transfer Pricing Bylaws.

(32) Article 18(C), Transfer Pricing Bylaws. See footnote (33).

5.6.1. Disclosure Form of Controlled Transactions

Section 1 of the Disclosure Form asks if the Taxpayer has any Controlled Transactions. If the response is “Yes”, the Taxpayer must provide more details about each of his Controlled Transactions separately (further details are included below). A Person subject to Zakat but not subject to Income Tax in KSA is not within the scope of Persons subject to the TP Bylaws (except if required to comply with CbCR obligations). Hence Zakat payers may respond with “No”.

NOTE: Persons subject to Zakat and not subject to income tax in KSA do not include “Mixed Companies”. For purposes of Transfer Pricing, Mixed Companies are treated as a Person Subject to Income Tax as a whole.

a. Subsection A:

1. The Taxpayer must select from the drop down menu the type of the Controlled Transaction (i.e. Tangible, Intangible, Services, Financial).
 - Tangible is a Controlled Transaction involving a transfer of tangible property such as goods or tangible assets
 - Intangible is a Controlled Transaction involving granting rights (such as right to use or derive benefits) or the transfer of Intangibles;
 - Services is a Controlled Transaction relating to the provision of services;
 - Financial is a Controlled Transaction that falls in the scope of Chapter 7 of these Bylaws.

For Controlled Transactions that may fall under more than one of the above categories, the category that most accurately describes the Controlled Transaction in light of its substance. This may be determined by examining various factors such as the actions undertaken by the Related Persons party to the Controlled Transaction in furtherance of it and the reasonably apparent purpose and objectives of the Controlled Transaction.

Where a Controlled Transaction includes several aspects that are so closely related that it is difficult to separate them, it is recommended to determine its nature based on the primary purpose of the Transaction. The ancillary or secondary aspects of the Controlled Transaction should also be indicated clearly.

(33) Any information required in the Bylaws for which no field is available should be entered in the free-form fields. Technical restrictions do not relieve Taxpayers from the obligation to submit all information required as per the Bylaws in a timely manner. If Taxpayers are unable to provide fully all the necessary information in the body of the forms, the missing information should be submitted to GAZT in any other way. GAZT recommends that it be provided in one single supplement attached with the declaration.

2. enter a description of the Controlled Transaction (e.g. “sale of goods” or “trademark license”).
3. include the legal name of the Related Person in relation to the specific Controlled Transaction disclosed.
4. Select the Tax Jurisdiction in which the Related Person resides (if different, organized/ incorporated must be provided)³⁴.
5. The revenue and/or expenses in relation to each Controlled Transaction should be included. The following is guidance for determining revenue and expenses:
 - Tangible: The transferred value of the underlying good (in principle, this would be the Arm’s Length Price of the goods reflecting its fair market value).
 - Intangible: the value for the use or transfer of the Intangible.
 - Services: the value of the service provided.
 - Financial: the interest expense (instead of the principal amount).
6. Select the TP method applied to the Controlled Transaction. (e.g. “CUP”)
 - The TIN and the registered address of the Related Person should be included, along with any Identifying Names and jurisdiction of establishment if different from the Tax Jurisdiction³⁵.
 - Description of the businesses and commercial activities of the Related Persons previously identified³⁶.
 - Legal owners of the Related Persons (including Tax Jurisdiction and jurisdiction of organization/establishment (if different)) and percentage ownership. If the beneficial owner is not the legal owner, the same information for the beneficial owner must also be provided³⁷.
 - Nature of the relationship of the Related Persons (i.e. Taxpayer vis-à-vis Related Person) must be provided³⁸.

Note: If the Taxpayer has more than one Controlled Transaction an additional row can be created through the “+” icon or deleted via the “x” icon. In the situation where the Taxpayer has more than one Transaction with the same Related Person (e.g. Transaction for the sale of goods and another for the provision of services) each Controlled Transaction should be reported separately, with all the above information included for each.

(35) Article 14(A)(1), Transfer Pricing Bylaws.

(36) Article 14(A)(6), Transfer Pricing Bylaws.

(37) Article 14(A)(3), Transfer Pricing Bylaws.

(38) Article 14(A)(5), Transfer Pricing Bylaws.

b. Subsection B

The Taxpayer must select whether the Taxpayer or the MNE Group has gone through a Business Restructuring by selecting "Yes" or "No". Business Restructuring refers to the cross-border (or domestic) reorganization of the commercial or financial relations between Related Persons, including the termination or substantial renegotiation of existing arrangements. For further Guidance on the reorganization, please see Chapter 9 of this Guideline.

c. Subsection C

The Taxpayer must provide financial information as per the declaration (total revenue, total Expense and net profit/loss).

d. Subsection D

The Taxpayer must respond as to whether TP documentation has been maintained in accordance with the TP Bylaws through selecting the applicable response.

- If "Yes" is selected two check boxes will appear which will display the option to select whether either or both the Local File and Master File were maintained in accordance with the TP Bylaws.
- If "No" is selected no checkbox will appear.
- If "Not applicable" is selected no checkbox will appear. This option is to be selected for Taxpayers that are not required to maintain the Master File and the Local File as described in this Guideline. Please note that these Taxpayers are still required to maintain the general transfer pricing documentation as described in Chapter 5.

e. Subsection E

It requires the Taxpayer to report whether or not the taxpayer participated in Controlled Transactions for no consideration or non-monetary consideration (such as barter). The Taxpayer can select "Yes" or "No".

- If the question is answered with "Yes" the Taxpayer must include a description of the Controlled Transaction and identify the Related Persons participating in it (including tax identification numbers, address and Tax Jurisdiction of residency). If there are more than one such Transaction additional rows need can be created by selecting the "+" icon.
- If the answer is "No" no further information is requested.

f. Subsection F

Information about the shareholder, partners or owners of Taxpayer must be listed in subsection F.

The details include legal names, TIN, address, Tax Jurisdiction of residence (and of incorporation/organization if different) and percentage shareholding or participation. With respect to publically listed companies, the Taxpayer Person should include separate information of shareholders who owns 5% or more of the shares. The other shareholdings which do not fall into this category should be bundled under the 'Public Ownership'.

5.6.2. Section 2: Country-by-Country Report Notification Form

Section 2 of the Disclosure Form relates to CbCR. The Taxpayer must indicate whether he is a part of an MNE Group that is required to file a CbCR (i.e. it meets the Statutory Consolidated Revenue Threshold). The answer must be 'Yes' if the SCRT is met.

- In subsections A-D the legal name, TIN, jurisdiction in which the CbCR is filed and Reporting-Year-end of the Ultimate Parent Entity (UPE) must be entered.
- In subsections E-H the legal name, TIN, jurisdiction in which the CbCR is filed and Reporting-Year-end (or financial year-end, whichever applies) of the Reporting Entity should be included.
- Select "Review" after the mandatory information is entered.

Note: where the Reporting Entity is a Taxpayer, the CbCR submission period should be determined based on the date of the MNE Group's Reporting-Year-end³⁹. Where section (C) of Article 18 of the Bylaws applies, the relevant Taxpayers must submit to the Authority the notification with respect to the Taxpayer who is the Reporting Entity and the names of the Taxpayers on whose behalf the CbCR will be submitted. There is no form for this notification at this time, thus submissions must be made by Taxpayers manually.

5.6.3. Chartered Accountant Certificate

Once Section 1 (the Disclosure Form of Controlled Transactions) and Section 2 (the CbCR Notification Form) are completed, the Taxpayer must attach the Chartered Accountant Certificate declaring that the Transfer Pricing policy of the MNE Group is consistently applied in relation to the Taxpayer in the KSA⁴⁰.

(39) Article 18(C), Transfer Pricing Bylaws.

(40) Article 14(C), Transfer Pricing Bylaws.

6.

Implementation

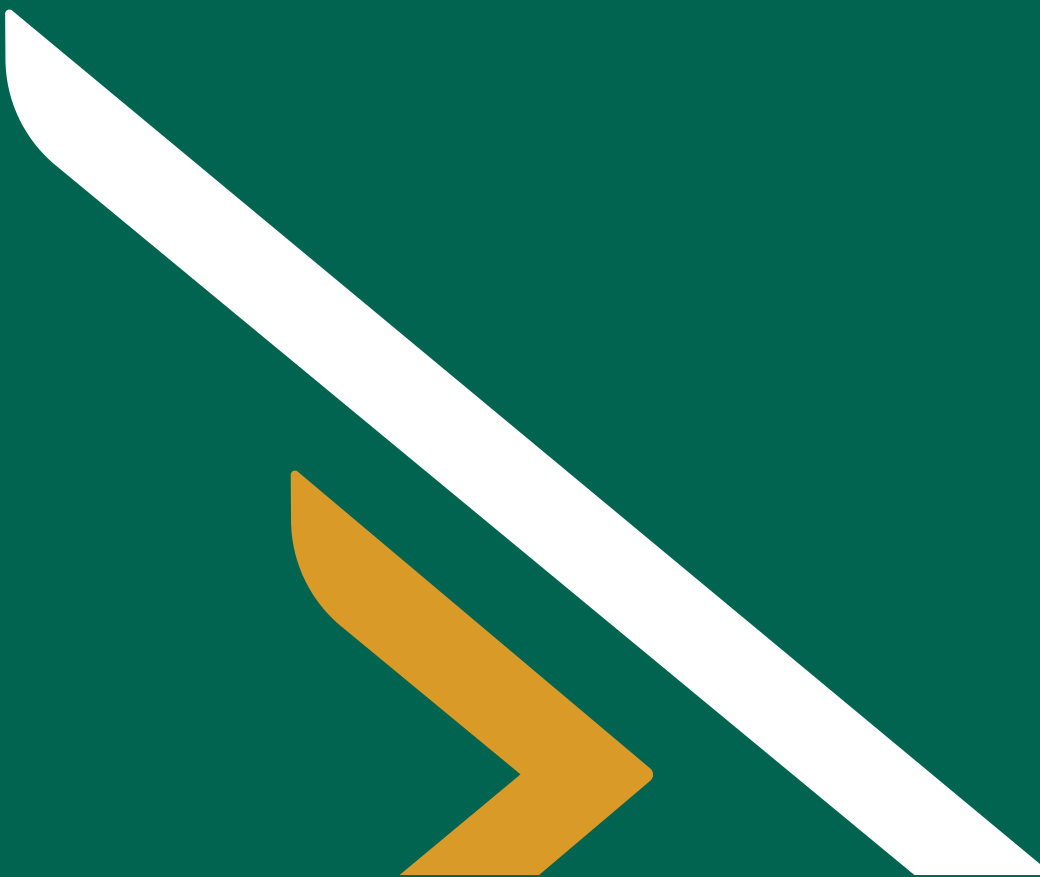

6. Implementation

This Chapter provides specific guidance on the implementation of the Arm's Length Principle in the KSA.

- The Controlled Transactions between Related Persons should be reported in their commercial accounts based on the existing accounting rules in the KSA. For this purpose, the Controlled Transactions are entered into the accounting systems of the Related Persons as this information is required when preparing certain records such as the balance sheet and profit and loss statement. This Chapter provides further guidance on this item.

6.1. General aspects

The Controlled Transactions between Related Persons should be reported (for accounting purposes) in their commercial accounts based on the existing accounting rules in the KSA. For this purpose, the Controlled Transactions are entered into the accounting systems of the Related Persons as this information is required when preparing certain records such as the balance sheet and profit and loss statement. These records are maintained for accounting purposes and therefore could include results that may or may not reflect the Arm's Length Priced Transaction, which may lead to potential adjustments.

For avoiding situations in which non-Arm's Length Transactions are reported in the commercial accounts, it should be considered to regularly monitor whether the Controlled Transactions entered into by the Related Persons satisfy the Arm's Length Principle. At the start of the financial year, most MNE Groups set the prices of Controlled Transactions according to their Transfer Pricing Policy in preparing their annual budget. During the given year, it is recommended that the actual results realized by the Taxable Person are monitored to ensure that the outcome is in line with the Arm's Length Principle as set out in previous Chapters.

It could be considered to apply a periodical adjustment mechanism to cover any unforeseen deviations in the budget and Arm's Length outcome. The forecasted data may be affected by, for instance, the economic environment or other circumstances affecting the results achieved by the Related Persons. By applying a periodical adjustment mechanism, Related Persons are better capable of monitoring and evaluating the Arm's Length nature of the Controlled Transaction and taking appropriate actions if needed. As a result, (significant) year-end adjustments may be avoided. Regardless of how Taxable Persons decide to implement an adjustment mechanism, this should be properly supported in Transfer Pricing documentation including without limitation, a valid benchmark study, available agreements and any other supporting documents. It is preferable that these periodical adjustments should be made by the Taxable Person before filing its tax return, as all Controlled Transactions must be reported in the Disclosure Form and the tax returns in accordance with the Arm's Length Principle.

Year-end adjustments are in principle allowed before closing the commercial accounts are for the financial/accounting year. In cases where (significant) year-end adjustments must be the Taxable Person during the last quarter of the Reporting Year or first month of the new Reporting Year, the year-end adjustments made should be properly classified and supported by the Taxable Person.

From a tax perspective, the Controlled Transaction should be in accordance with the Arm's Length Principle. If required, the non-Arm's Length Controlled Transaction should be reconstructed as an Arm's Length Controlled Transaction for the purpose of calculating the taxable income of the Taxable Person and eventually taxing such income in the KSA. Under these circumstances, the Authority could impose an adjustment to ensure that the Controlled Transactions of Taxable Persons are consistent with the Arm's Length principle⁴¹.

(41) Article 12, Transfer Pricing Bylaws; Article 63, Income Tax Law.

7.

Specific Guidance: Financial Transactions



7. Specific Guidance: Financial Transactions

This Chapter provides specific guidance on Financial Transactions.

- For the financial Transactions the same initial rules apply: the conditions must be checked against the Arm's Length Principle. As such, this Chapter provides additional guidance on various examples of financial Transactions which Related Persons could enter into given their more specific nature.
- This Paragraph solely serves as an indication of the financial Transactions that may occur between Independent Persons and therefore other financial Transactions not explicitly described in this Paragraph may also fall under the scope of this Transfer Pricing Guideline.

7.1. Loan Transactions

For a loan Transaction between Related Persons all the conditions of the Transactions should be considered including the risk allocation and the price. The starting point for this is identifying the Controlled Transaction (as explicated in Chapter 4 of this Guideline).

For determining the Arm's Length Nature of the loan Transaction between Related Persons the two-sided perspective should be considered, i.e. the perspective of an independent lender and independent borrower. The independent lender wants to minimize its risk, also considering the functionality in the market and risk appetite. This means that the lender will base its decision to provide a loan on whether the independent borrower will be able to repay the loan and the interest charged on it. The creditworthiness of the borrower is therefore decisive in determining if the independent lender would be willing to grant the loan.

Creditworthiness is often expressed in credit ratings. The credit ratings as provided by independent credit agencies can be used as a reference point to determine the creditworthiness. Ratings which range from AAA/Aaa to BBB-/Baa3 generally denote high to satisfactory creditworthiness which could be characterized as "investment grade". Under these credit ratings, the likeliness that the independent borrower will default on a loan is deemed to be low. Borrowers with a credit rating lower than BBB-/Baa3 could be regarded as non "investment grade" since the likelihood that they will ultimately be unable to pay

interest and repay the loan is considered to be high. These credit ratings are based on certain financial indicators, depending on the approach taken in determining the rating itself. Ideally, a stand-alone credit rating for the borrowing entity should be established.

Only in special situations would an independent lender be willing to accept a lower credit rating than BBB-, for instance an independent lender with a diversified loan portfolio or if certain additional conditions are met. Considering this, the Related Person that is providing the loan to the borrowing Related Person that is considered to have a low creditworthiness should demonstrate that this loan was agreed under Arm's Length Conditions. Nevertheless, this should be carefully examined since in practice Persons with a lower credit rating than investment grade is able to attract funding from Financial Institutions and Independent Persons.

The independent borrower will strive to optimize the financing of its business activities efficiently in such a way that capital costs are minimised. As a result, the debt to equity ratio is important for the level of cost of capital. This is especially important since it could be advantageous to finance part of the business activities with borrowed capital as this increases the return on invested equity capital and the interest payment could qualify as tax-deductible. On the contrary, excessive costs incurred in raising (borrowing) capital may result in a reduction of the return on invested equity capital.

Special attention should be paid to situations in which due to entering into the loan Transaction, the borrowing Person becomes insufficiently creditworthy. Under these circumstances, the Related Persons must demonstrate that the loan has been agreed under Arm's Length conditions.

In addition to credit rating, other facts and circumstances of the loan Transaction need to be considered to determine the Arm's Length Nature of the loan. For example, interest rate is generally influenced by term, pre-payment options, subordination, currency, fixed or floating base rates, etc. As with any Transaction, all conditions should be evaluated against the Arm's Length Principle for which the starting point is examining the relationship that borrowers and lenders have in financial Transactions in case they would enter into a comparable Independent Transaction. For example, that collaterals may be requested and required in case of increased risks with respect to the Transaction.

An adjustment for risk allocation may be appropriate given the specific facts and circumstances regarding the loan Transaction. In this respect, an annual reassessment of the facts and circumstances underlying the Transaction, such as an evaluation of the creditworthiness of the borrower, needs to take place in order to ensure that a consistent approach is followed and that, for example, no temporary balance sheet enhancement takes place by means of an injection or withdrawal of capital.

If the loan Transaction cannot be made at Arm's Length by adjusting the conditions and/or the price, this may lead in extreme cases to disregarding/requalification of the complete loan or partly.

7.2. Guarantees

A guarantee is a legally binding agreement under which the guarantor agrees to pay any or all of the amounts due on, but not limited to, financial instruments (such as loans), financial performance or other obligations, in the event of non-payment by the borrower, non-performance or non-fulfilment of its obligations by the guaranteed Person.

In some cases, guarantees in relation to loan agreements or other obligations are in force between Related Persons. In these cases, it must be investigated whether Arm's Length conditions can be found under which Independent Persons acting in a commercially reasonable manner would be willing to enter into such a guarantee Transaction. The evaluation of this financial Controlled Transaction against the Arm's Length Principle should be considered from the perspective of the Related Persons issuing the guarantee and the perspective of the Related Person for which the guarantee is issued. Furthermore, it should be assessed whether the Related Person to whom the guarantee is issued actually requires a guarantee and would be prepared to pay a fee to obtain the guarantee.

In general, guarantees are extended to increase the borrowing capacity or reduce the interest rate of a Related Person by increasing the creditworthiness of the guaranteed Related Person, as in most cases the credit rating of the guarantor is passed down to the debtor. This is beneficial for the debtor as this may result in more beneficial terms and conditions in relation to the loan (e.g. better interest rate) or even allowing to obtain resources that

it could not access without having the guarantee. The guarantees between the Related Persons must be evaluated against the Arm's Length Principle.

If a guarantee is provided by the Related Person, the ability of the guaranteed Related Person to obtain more favourable loan terms without an explicit guarantee than a comparable Independent Person would obtain (in other words, obtaining the favourable terms solely on the basis that it is part of the MNE Group (implicit guarantee)). The amount identified under this approach should not be seen as a service for which a fee must be charged. If favourable conditions are obtained due to an explicit guarantee given by the Related Persons (for which an Independent Person would be willing to pay), this will be deemed to be a service for which a fee must be charged in accordance with the Arm's Length Principle.

7.3. Cash management, optimization and cash pooling

Departments within a MNE may be engaged in cash management and optimization of cash flows on behalf of Related Persons. This department effectively manages the liquidity of the MNE and ensures that the use of available liquidity in the group is optimized. A more involved option of cash management and optimization could be achieved by establishing a cash pool structure. Cash pool structures are highly specific in nature and are generally not observed between Independent Persons. As such, specific Transfer Pricing elements need to be observed.

A wide range of (key) objectives are related to the establishment of such cash pool which are not solely tax driven, however, the tax aspects should be considered in the evaluation of the Arm's Length Principle. For the cash pool the following Transfer Pricing aspects should be considered:

- The debit and credit interest on the cash used / made available by the Related Persons;
- The remuneration for the cash pool leader. This remuneration should reflect the functional profile (i.e. functions performed, risk assumed, and assets used) of the cash pool leader. For the risk section, the management, control and financial capacity to bear the risk are important factors to consider; and
- Allocation of the cash pool advantage divided over the Related Persons. These advantages could be related to the reduction of costs and more favourable interest rates due to

the economies of scale. This advantage should be equally divided based on the value contributions made by the cash pool members and cash pool leader respectively with regard to obtaining the advantage derived from the cash pool activities.

- Since cash pool Transactions are of a short term by nature, it is important to determine characteristics of the Transactions within the cash pool, namely the maturity of the loans provided, and the loans attracted within the cash pool arrangement. In case deposits to the cash pool are provided for a longer term or funds are attracted from the cash pool for a longer term, this could lead to a change of character of the Transaction from short-term to mid- or long-term. This could accordingly mean that the interest rates and other terms of these loans will have to be changed to satisfy the Arm's Length conditions.
- All of the above aspects should be in accordance with the Arm's Length Principle. In addition to the above, other Controlled Transactions should be considered that potentially affect the cash pool structure in place within the MNE. As an example, the guarantees outlined in Paragraph 7.2. to facilitate or supplement the cash pool may have an impact on the Transfer Pricing aspects that should be considered.

7.4. Factoring and Invoice Discounting (assignment of accounts receivable)

Factoring and invoice discounting are both alternative methods to improve liquidity and cash-flow when there is an immediate need for funds. Factoring is a financial Transaction in which a Person sells its accounts receivables to a third party.

In general, the buyer and assignees of accounts receivables (factoring companies) provide various services such as financing, accounts receivable management and credit risk assumption.

The accounts receivables are normally sold to the buyer at a discount. The buyer assumes title to the accounts receivables and bears the risk of default. Further, the buyer has no Factoring recourse against the seller. When the accounts receivable is paid, the difference between the payments received and the discounted price for which the accounts receivable are purchased constitute the factoring fee.

For the factoring arrangement between Related Persons it is important to assess the Arm's Length Nature of the discount under which the account receivables are sold, since the Arm's Length factoring fee for the Person performing the factoring activities will consist of the difference between the payments received and the discounted price for which the accounts receivable are purchased. In general, this factoring fee will have to consist of an Arm's Length remuneration for the activities performed and the risks assumed, whilst interest charged (e.g. for late payments on the accounts receivable) will have to be reported separately. Additionally, the factoring arrangement between Related Persons should be properly documented by means of the contractual factoring agreement, the Functional Analysis and the economic analysis.

On the contrary, invoice discounting involves a person with customer receivables using these as collateral for borrowing from a lender, without any sale of those receivables to the Lender. The Lender therefore does not assume risk of customer non-payment.

The Person acting as Lender may charge a fee for making the facility available and on the interest or rate of return for the amounts loaned. The Arm's Length remuneration should be determined with each of these elements reflected.

7.5. Securitization

Securitization is the process of issuing new securities backed by existing assets such as loans, mortgages, credit card debt, or other assets, including accounts receivable.

Securitization takes place by means of the establishment of a Person for this specific activity, with the purpose to isolate certain loans, debts, company assets or operations. In most situations, securitization takes place to free up regulatory capital, e.g. the assets that banks are required to hold by their financial regulators to remain solvent. In addition, securitization can offer issuers higher credit ratings and lower borrowing costs.

The basis of securitization is the selling of cash flows relating to the loans, debts or assets to independent investors as securities through the securitization Person. The securities

can be issued with either a fixed interest rate or a floating rate. Investors are repaid from the principal and interest cash flows collected from the underlying debt and redistributed through the capital structure of the new financing. Securities backed by receivables are essentially asset-backed securities.

The loans, mortgages, credit card debt, or other assets, are mostly sold to the securitization Person against a discount and creates, besides the advantages mentioned above, an advance cash flow advantage.

With respect to the Arm's Length remuneration of the securitization Person, the following aspects are important to take into consideration. Profits arising from the activities of a securitization Person should be captured under the regular taxation rules and will depend on the funding of the securitization Person, as well the activities performed, mostly consisting of providing services.

Another element to take into account that will influence the remuneration of the securitization Person, as well as the profit that the asset selling entity generates, is the discount rate that might be applied on the price of the assets that are sold to this Person.

In practice the Arm's Length remuneration of a securitization Person will at a minimum consist of an Arm's Length return on its equity, taking into account the risk it is bearing, as well as a remuneration for the activities performed.

7.6. Hedging

The MNE can decide to centralize its risk management in a Related Person to ensure that the risks can be monitored and managed more effectively (i.e. centralized treasury entity). As a result, the MNE may have an overview of the risks assumed in a Controlled Transaction between Related Persons and this may allow opportunities for risk diversification within the group. The Related Person executing the hedging activities could enter into derivatives contracts with independent Financial Institutions to mitigate potential risks, e.g. market risk or foreign exchange risk.

The Related Person performing these hedging activities should be remunerated on an Arm's Length Basis considering its functional profile (mainly the assumption of risks for the group) and the value contributed to the internally hedged Transactions. If this centralized treasury unit solely operates as service provider and thereby intermediating Transactions with independent financial institutions, this should be reflected in the remuneration received. It is important that the Person performing these hedging activities has the requisite skills and experience at its disposal, as well as sufficient financial capacity to take on the hedging.

7.7. Captive insurance

A Person sometimes acts as an internal (re)insurer for Related Persons in the MNE. This is often centralized in a captive insurance company that provides insurance-type services exclusively or mainly to members of the MNE Group. The business objective of establishing the captive insurance in general leads to an insurance cost reduction by pooling the risks of group members due to a reduction in volatility.

The main purpose of a captive insurance company within a MNE is to avoid using traditional commercial insurance companies, which have volatile pricing, and may not meet the specific needs of the Person. By creating a dedicated insurer (i.e. internal insurance Person) within a MNE, the MNE Group can reduce their costs, insure difficult risks, have direct access to reinsurance markets, and increase cash flow. By means of a captive insurance company, the MNE Group is indirectly able to evaluate the risks of Related Persons, write policies, set premiums and ultimately either return unused funds in the form of profits, or invest them for future claim pay-outs.

Factors that may have an important role in establishing the captive insurance company are stabilizing the premiums that are paid by the Related Persons of the MNE, gaining access to the reinsurance markets or difficulty or impossibility of getting insurance coverage for certain risks.

In some cases, the captive insurance company does not perform similar activities which are characteristic for a professional (re)insurer such as product development, marketing and sales, acceptance of insured Persons, asset/liability management and development

of an (independent) reinsurance policy. Besides, the captive insurance company may not be engaged in active diversification outside the MNE of the risks present in relation to the internal (re)insurance activities, but only engaged in a “passive” diversification within the group. Under these circumstances, only limited remuneration for the captive insurance may be appropriate for the insurance-type services performed.

For the above, the commercial and financial relations between the Related Persons as outlined in Chapter 4 should be identified, for determining whether the insurance activities performed by the captive insurance company actually exist. Accordingly, the initial questions are whether the Transaction under consideration could potentially be characterized as insurance.

After the insurance Transaction is recognized and accurately isolated, the Arm’s Length Price of captives should be determined whereby the most appropriate Method should be selected in accordance with Chapter 4 of this Transfer Pricing Guideline.

8.

Specific Guidance: Intangibles

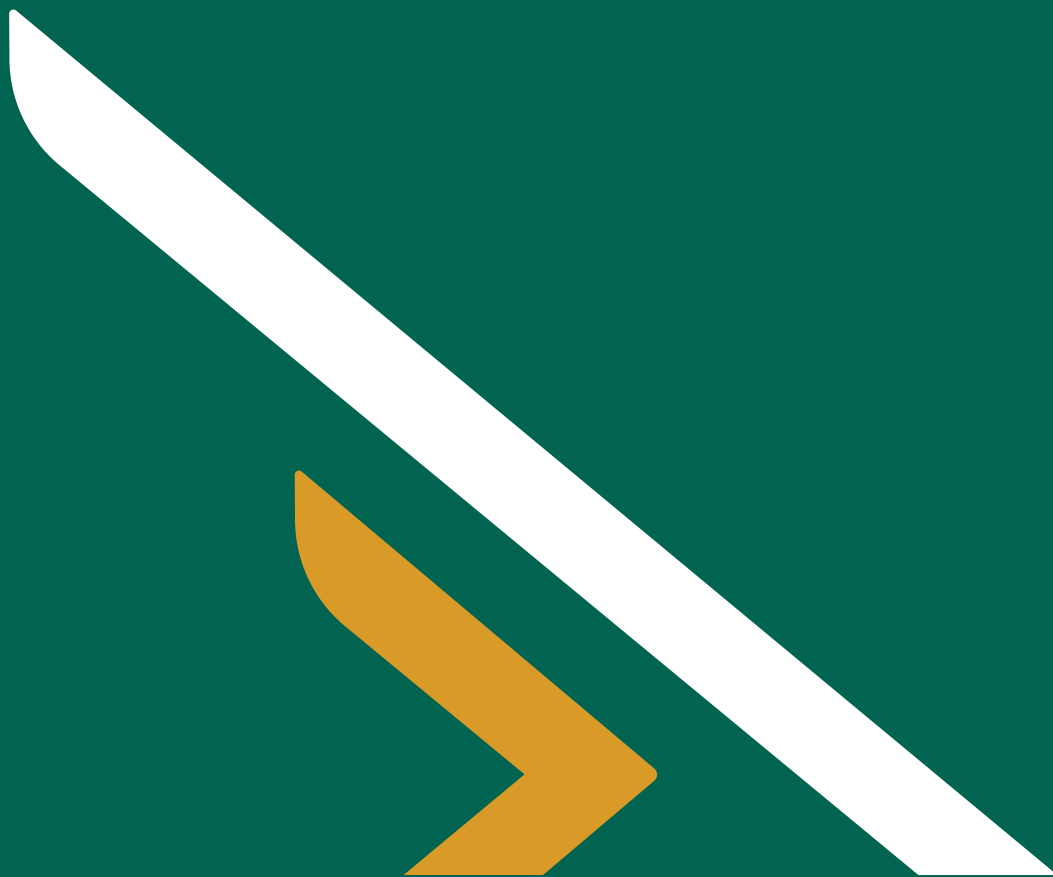

8. Specific Guidance: Intangibles

This Chapter includes specific guidance on Intangibles. It includes a specific framework on relevant aspects of analysing Intangibles.

The specific framework refers to the identification of the Intangible and the identification of the economically significant risks associated with Development, Enhancement, Maintenance, Protection and Exploitation (“DEMPE”) of the Intangible.

The full contractual arrangements should be the starting point of the Transfer Pricing analysis for Intangibles. In relation to the DEMPE of the Intangibles, the Persons who perform the relevant functions, use the assets and/or assume the risk must be identified.

Appendix 12, 13 and 14 provide examples on specific guidance on Intangible Transactions.

8.1. What is an Intangible?

The purpose of this Chapter is to provide specific guidance to determine Arm's Length conditions for Transactions that involve the use or transfer of Intangibles.

The word "Intangible" intends to address something which is:

- not a physical asset or a financial asset;
- which is capable of being owned or controlled for use in commercial activities; and
- whose use or transfer would be compensated had it occurred in a Transaction between Independent Persons in comparable circumstances.

General examples of items that under specific circumstances may constitute an Intangible are included below for illustration purposes. This listing should not be used as a substitute for a detailed analysis and is not intended to be non-exhaustive.



Intangible

Intangible for TP purposes

- Patents
- Know-how and trade secrets
- Trademarks, trade names and brands
- Rights under contracts and government license
- Licenses and similar limited rights in intangibles

Not an Intangible for TP purposes

- Group synergies
- Market specific advantages
- Assembled workforce

8.2. Applying the Arm's Length Principle with respect to Intangibles

In Transfer Pricing cases involving Intangibles, the determination of the Person or Persons within an MNE Group which are entitled to share in the returns derived by the Related Persons from exploiting Intangibles is crucial. There are two general types of Transactions where the identification and examination of Intangibles will be relevant for Transfer Pricing purposes. These are:

1. Transactions involving transfers of Intangibles or rights in Intangibles; and
2. Transactions involving the use of Intangibles in connection with the sale of goods or the provision of services.

In applying the arm's length principle to Intangibles the general guidance included in Chapter 4 should be taken as a start. Specifically, the following steps for analyzing Intangibles from a Transfer Pricing perspective are relevant:

-
- 1 Identify the Intangible used or transferred;
 - 2 Identify the economically significant risks associated with Development, Enhancement, Maintenance, Protection and Exploitation ("DEMPE") of the Intangible;
 - 3 Identify the full contractual arrangements;
 - 4 Identify the Persons performing functions, using assets or managing (i.e. controlling) risks in relation to the DEMPE of the Intangible;
 - 5 Confirm consistency between the contractual arrangements and the conduct of the Persons, and determine whether the Person assuming the economically significant risks also controls the risk in relation to the DEMPE of the Intangible;
 - 6 Determine the Controlled Transactions related to the DEMPE of the Intangible(s) in light of legal ownership, other relevant contractual arrangements, conduct of the Persons and the functions performed, risks assumed, and assets used by the Persons involved;
 - 7 Determine the Arm's Length Pricing for the use or transfer of Intangibles or the non-recognition of the Transaction.
-

8.2.1. Step 1: Identify the Intangible used or transferred

The Transfer Pricing analysis should not focus on accounting or legal definitions of Intangibles as such. Instead the specific Intangibles and the conditions of the Controlled Transactions, of which the identified Intangibles underlie, should be determined, in addition to the comparability of their terms and conditions with those that would be agreed upon between Independent Persons in comparable circumstances.

8.2.2. Step 2: Identify the economically significant risks associated with Development, Enhancement, Maintenance, Protection and Exploitation (“DEMPE”) of the Intangible;

The analysis of risk should follow the six-step process as included in Chapter 4 of this guidance. For Intangibles the identification of risk should specifically focus on the DEMPE of the Intangible.

8.2.3. Step 3: Identify the full contractual arrangements;

The contractual arrangements and legal rights are the starting point for any Transfer Pricing analysis of Transactions involving Intangibles.

The terms of a Transaction may be found in written contracts, public records (e.g. patent or trademark registrations), or in correspondence and/or other communications of the Persons. Moreover, it is relevant to determine the contractual rights and obligations of the Persons, including the contractual assumption of risks between the Related Person.

In case no written terms of a Transaction exist, the analysis should focus on the conduct of Persons and the facts as existing.

In all cases, the substance of the Controlled Transactions supersedes form.

The legal owner will be presumed to be the sole owner of the Intangible for Transfer Pricing purposes, unless there is reason to believe otherwise. However, legal ownership

of Intangibles in itself does not mean that this owner is entitled to the rights to retain all returns and economic benefits derived from the exploitation of the Intangible. This is so even though such returns may initially accrue to the legal owner due to the legal ownership.

8.2.4. Step 4: Identify the Persons performing functions, using assets and managing (i.e. controlling) risk in relation to the DEMPE of the Intangible;

It is important to identify the Persons who perform functions, use assets and manage risk in relation to the DEMPE of the Intangible to obtain an understanding of the actual conduct of the Related Persons. Based on the framework included in Chapter 4 of this Guideline the Persons involved should receive an Arm's Length remuneration for the functions performed.

With respect to Intangibles, the focus on DEMPE is important to determine the value of the contributions made by the Persons to the Intangibles. The relative importance of contributions (DEMPE) to role played in value creation for Intangibles by the Related Person through the functions performed, assets used, and risks assumed may vary depending on the circumstances of the case at hand.

It is not essential that the legal owner directly perform all of the functions related to DEMPE in order to retain or be attributed a portion of the return or benefits derived from the Intangible(s). Some functions could be outsourced to third parties. These functions should, however, be controlled by the owner in order to retain or attribute a portion of the return to the legal owner.

If the Related Person does not control nor performs any of the functions related to the DEMPE of the Intangible, the legal owner would not be entitled to any ongoing benefit attributable to the outsourced functions.

The Person that provides funding, but does not control the risk or perform any of the functions with respect to the funded activity or Intangible asset, generally does not receive anticipated returns similar to the returns received by an investor who performs and controls functions and controls important risks of the funded activity.

Where a Related Person providing funding exercises control over the financial risk associated with the provision of funding, without the assumption of and control over any other specific risks, it is generally expected that such Related Person will receive only a risk-adjusted return on its funding. Further guidance on financing is provided in Chapter 7.

Eventually, the assumption of risk will determine which Person or Persons will be subject to the consequences if the risk materializes. It is especially important to ensure that the Group member(s) asserting entitlement to returns from assuming risk actually bear responsibility for the actions that need to be taken and the costs that may be incurred if the relevant risk materializes.

Specific risks that may be important to consider in a Functional Analysis in relation to Intangibles are:

- Risks on development of Intangibles (including the risk that costly R&D or marketing will prove to be unsuccessful). Under these circumstances, the timing of when the investment is made in the development process should be considered;
- Risk that a product becomes obsolete (e.g. in case of technological developments);
- Infringement risk;
- Product liability risk;
- Exploitation risks (e.g. uncertainties in relation to the returns generated by the Intangible)

The extent to which these risks occur and their significance will depend on the facts and circumstances.

8.2.5. Step 5: Confirm consistency between the contractual arrangements and the conduct of the Persons and determine whether the Person assuming the economically significant risks also controls the risk in relation to the DEMPE of the Intangible;

Based on steps 3 and 4 it should be confirmed whether the contractual arrangements and the conduct of the Persons are consistent. If so, the conduct of the Related Persons that is consistent with the contractual arrangements can, in principle, be taken as the basis for determining the Controlled Transactions.

If the contractual arrangements are not consistent with the conduct of the Related Persons, then the conduct of the Related Persons should be taken as a basis for determining the actual Controlled Transactions and their nature. If the conduct of the Related Persons is taken as the basis, this should be substantiated with an extensive and detailed Functional Analysis with a specific focus on the Intangible.

8.2.6. Step 6: Clearly determine the actual Controlled Transactions related to the DEMPE of the Intangible(s) in light of legal ownership, other relevant contractual arrangements, conduct of the Persons and the functions performed, risks assumed and assets used by the persons involved;

The clear determination of the actual Controlled Transactions should follow from the above-mentioned steps and the framework included in Chapter 4 of this guidance. Once the actual Controlled Transactions are determined the pricing can be set.

For the clear determination it is important to review the options realistically available to the Related Persons, keeping in mind a two-sided approach (from both the buyer's and the seller's perspective). After all, based on the Arm's Length Principle, Related Persons are expected to strive for profit maximization. Independent Persons will normally enter into a Transaction relating to Intangibles only if they can both expect an increase in profit.

8.2.7. Step 7: Determine the Arm's Length Pricing for the use or transfer of Intangibles or the non-recognition of the Transaction.

8.2.7.1. Determining price for the use of Intangibles

For the use of Intangibles it may be possible to identify a reliable Uncontrolled Transaction. In practice a CUP may be applied for the use of certain Intangibles. In such case comparability adjustments may be required with respect to differences in local markets, locational

advantages, business strategies, assembled workforce, corporate synergies and other similar factors (e.g. the remuneration for the use of Intangible assets by Taxpayers may be determined using royalty percentages from various databases). The question, however, is whether this publicly available information is sufficiently detailed to conduct a comparability analysis in a responsible manner. The Authority will therefore critically assess the use of such databases. Alternatively the PSM may prove to be the most appropriate Method for the use of Intangibles. The other Methods (as included in Chapter 4) are generally less appropriate to apply for the use of Intangibles.

8.2.7.2. Determining price for the transfer of Intangibles

Intangibles (including limited rights in Intangibles) may be transferred individually or in combination with other Intangibles. It is important to consider the relative contribution to value creation where different Related Persons hold rights in the Intangibles used. As such, the characteristics of the Intangible together with the existence of risks related to the likelihood of obtaining future economic benefits from the transferred Intangibles must be considered.

Care should be taken in the application of the Transfer Pricing Methods in a matter involving the transfer of Intangibles or rights in Intangibles. One-sided methods, including the RPM and the TNMM, are generally not reliable methods for directly valuing Intangibles or for ongoing pricing involving Intangibles. The use of Transfer Pricing Methods that seek to estimate the value of Intangibles based on the cost of Intangible development is generally discouraged.

For a transfer of Intangibles it may be possible to use valuation techniques to estimate the Arm's Length Price. Further guidance on the use of valuation techniques and application of price adjustment provisions is included in Chapter 10.

8.2.7.3. Non-recognition of a transaction or elimination of a disadvantage

Only in rare occasions will a Transaction be able to be ignored for Transfer Pricing purposes.

A disadvantage of entering into a Transaction which is not favorable for both Related Persons should in principle be eliminated for Transfer Pricing Purposes.

For example, if Intangibles are transferred to a Related Person that does not add value to the relevant assets because it lacks the required functionality and is therefore unable to control the risks relating to the asset, the Transaction will not satisfy the Arm's Length Principle. In this example it is a realistically available and more attractive option for both the seller and the buyer not to enter into the Transaction. The total operating profit that the Persons would achieve jointly is not higher than if the transfer had not occurred. Because the transfer would be accompanied by extra costs (for example, the drafting of contracts), the joint operational result is expected to be even lower than if no transfer had taken place.

On the basis of the Arm's Length Principle, the disadvantage of using conditions that deviate from conditions that would have been agreed by Independent Persons, should be eliminated from the taxable profit of the seller. This disadvantage is the difference in profit compared to a situation where the transfer did not take place. Further guidance on termination payments is set out in Chapter 10.

8.3. The purchase of shares of an Independent Person followed by business restructuring

In practice, it often happens that an MNE Group buys shares of an Independent Person, after which the acquired Person's Intangible Assets are transferred to a Related Person. It is important to determine whether, in addition to the legal ownership of the Intangible Assets, the associated functionality and the related risks are transferred. For more information on Business Restructuring reference is made to Chapter 9.

The acquisition documentation (with the exception of certain aspects that Taxpayers can show to be irrelevant for tax purposes), which is usually held by the acquirer, is an essential part of the information that could support the price of the Intangible Assets transferred. This should be available upon request to the Authority. Furthermore, the content of the acquisition file should be appropriately reflected in the TP documentation of the Taxpayer. Although the price of the purchased shares is, presumably, at Arm's Length because the seller is an Independent Person, this does not necessarily mean that the value of the shares for the buyer is equal to this price. On the contrary, the buyer will generally only make a purchase if it expects that the value created by the acquisition will be greater than the purchase price. The value of the shares is to some extent subjective as it reflects an assessment of the risk that the buyer assumes at the time of transfer. Thus, this makes the value volatile over time. When determining the value of a transferred assets, a good indicator of the minimum price could be the value that the buyer of the shares has attributed to the Intangible Assets of the acquired juridical Person.

In the case of a transfer of the Intangible Assets, the seller must take into account the fact that, in contrast to a transfer of shares, income tax will have to be paid on any profit resulting from the transfer of the assets. In general, the seller will take into account this income tax payable on the profit and would want to obtain - at a minimum - a return on sales equal to the value it attributes to the Intangible Assets plus the tax due on a possible profit.

9.

Specific Guidance: Business Restructuring



9. Specific Guidance: Business Restructuring

This Chapter provides specific guidance on Business Restructurings.

- A Business Restructuring is defined as a cross-border or domestic reorganization of the commercial or financial relations between Related Persons, including the termination or substantial renegotiation of existing arrangements. Business Restructurings may often involve the centralization of Intangibles, risks, or functions with the profit potential attached to them.
- Business Restructuring has an impact on the profit potential of a Person. The “profit potential” means expected future profits. To determine whether a compensation is applicable on the upon a Business Restructuring, a comparison of the pre-Business Restructuring and post-Business Restructuring functions performed, risks assumed, and assets used is important to see the impact on profit potential.

9.1. What may constitute a Business Restructuring?

Business Restructurings may often involve the centralization of Intangibles, risks, or functions with the profit potential attached to them.

As an example, a Person part of a MNE Group is engaged in the distribution of televisions whereby it procures the televisions from Independent manufacturers and hereafter sells the products to customers in the local market. The Person performs all the required activities (e.g. owning inventory etc.) and bears the associated risks (e.g. price risk, credit risk etc.) for its own account. Due to a restructuring within the MNE Group, the Person no longer performs distribution activities but instead converts to a sales representative of a Related Person. In this new role, the Person solely provides product information regarding the televisions and customer services to the customers in the local market.

Business Restructuring could also include situations in which more Intangibles or risks are allocated to operational Persons (e.g. manufacturers or distributors). Business Restructurings can also consist of the rationalization, specialization or despecialization of operations (e.g. manufacturing sites and/or processes, research and development activities, sales, services), including the downsizing or closing of operations.

9.2. Understanding the Business Restructuring

The application of the Arm's Length Principle to a Business Restructuring must start, as for any Controlled Transaction, with the identification of:

- the commercial or financial relations between the Related Persons involved in the Business Restructuring; and
- the conditions and economically relevant circumstances in relation to those relations

Based on this, the Controlled Transactions comprising the Business Restructuring can be properly defined.

Important aspects of identifying the commercial or financial relations relevant to determining the Arm's Length conditions of Business Restructuring are analyzed based on the following:

- Determination of the Transactions before and after the Business Restructuring based on the functions performed, assets used, and risks assumed;
- The business reasons for and the expected benefits following the Business Restructuring, including the role of synergies;
- Determination of the other options realistically available to the Related Persons.

These three aspects are further elaborated in detail below. In addition, guidance is provided on the reallocation of risks and profits.

9.2.1. Determination of Transactions compromising the Business Restructuring

It is important to accurately determine the Transactions occurring between the restructured Person and one or more other members of the group. Based on this determination it can be assessed whether, based on the application of the Arm's Length approach, a compensation should be due.

Business Restructurings often result in local operations being converted into low risk operations (e.g. "low risk distributors", or "low risk contract manufacturers") and being remunerated with a relatively low (but generally stable) return on the grounds that the economically significant risks are assumed by another Person to which the profits or losses associated with those risks are allocated. For this reason, an examination of the allocation

of risks between Related Persons before and after the restructuring is an essential part of the Functional Analysis.

It is crucial to determine which Person assumes specific risks before the Business Restructuring and which Person assumes specific risks after the Business Restructuring. Examples of risks that may be relevant are:

- Inventory risk: it is relevant to examine not only the contractual terms, but also the conduct of the Persons (e.g. whether any inventory write-downs are taken before and after the restructuring, whether there is any indemnification for those inventory write-downs, which Person or Persons perform risk control functions and have the financial capacity to assume the risks).
- Credit risk: e.g. bad debt risk.

Appendix 15 provides some further examples on the above-mentioned risks.

In any analysis of risks in Controlled Transactions, one important issue is to assess whether a risk is economically significant, i.e. it carries significant profit potential, and, as a consequence, whether that risk may explain a significant reallocation of profit potential. The significance of a risk will depend on the likelihood of the risk materializing and the size of the potential profits or losses arising from the risk. Further guidance on the framework for analyzing risk is included in Chapter 4.

9.2.2. Business reasons and the expected benefits

In practice, the pressure of competition in a globalized economy, savings from economies of scale, the need for specialization and the need to increase efficiency and lower costs have all been described as important in driving Business Restructurings.

Some of the reasons reported by businesses for restructuring include the wish to maximize synergies and economies of scale, to streamline the management of business lines and to improve the efficiency of the supply chain, taking advantage of the development of web-based technologies that has facilitated the emergence of global organizations. Furthermore, Business Restructurings may be needed to preserve profitability or limit losses, e.g. in the event of an over-capacity situation or in a downturn economy.

It is recommended that the Taxpayer documents the rationale and other considerations for the Business Restructuring and provides specific considerations on anticipated synergies and/or other specific circumstances and assumptions. This should be documented at the time the Business Restructuring (or company takeover) is decided or implemented. This documentation is likely to be produced at the group level for non-tax purposes to support the decision-making process of the Business Restructuring. The requisite TP documentation should reflect the rationale for the Business Restructuring and provide further details on the specific considerations (e.g. synergies) and the assumptions on which it is based.

It is noted that the fact that a Business Restructuring may be motivated by anticipated synergies does not necessarily mean that the profits of the MNE Group will effectively increase after the Business Restructuring.

It may be the case that enhanced synergies make it possible for the MNE Group to derive additional profits compared to what the situation would have been in the future if the restructuring had not taken place, but there may not necessarily be additional profits compared to the pre-Business Restructuring situation. This may be applicable if the Business Restructuring is needed to maintain competitiveness rather than to increase it.

In addition, expected synergies do not always materialize – there can be cases where the implementation of a global business model designed to derive more group synergies in fact leads to additional costs and less efficiency.

9.2.3. Other options realistically available to the Persons

In applying the Arm's Length Principle it is not sufficient that the Business Restructuring makes commercial sense for the group as a whole. The arrangements must be at Arm's Length at the level of each individual Taxpayer. In this respect the rights, other assets and expected benefits from the arrangements (i.e. any consideration of the post-Business Restructuring arrangement and, if applicable, any compensation payments for the Business Restructuring itself) should be considered.

Independent Persons will generally only enter into a Transaction if it does not make them worse off than their next best option. Consideration of the other options realistically

available may be relevant to comparability analysis, to understand the respective positions of the Persons.

There are situations where the restructured Person would not have had a clear and more attractive option realistically available to it than to accept the conditions of the restructuring, e.g. a contract termination – with or without indemnification. Therefore understanding the options realistically available to the Persons is an important part of understanding the Business Restructuring from an Arm’s Length perspective.

9.3. Relocation of profit potential as a result of a Business Restructuring

Business Restructurings have an impact on the profit potential of a Person. The “profit potential” means “expected future profits”, although in some cases it may encompass losses.

In order to determine whether there is a transfer of profit potential, the use of valuation techniques may be considered helpful in estimating the Arm’s Length Pricing. In Chapter 10 separate guidance is provided with respect to the use of valuation techniques and a Price Adjustment Clause.

An independent Person does not necessarily have the right to receive compensation when a change in its business arrangements results in a reduction of its profit potential or expected future profits. The Arm’s Length Principle does not require compensation for a mere decrease in the expectation of a Person’s future profits. When applying the Arm’s Length Principle to Business Restructurings, the question is whether:

- there is a transfer of something of value (an asset or an ongoing concern); or
- a termination or substantial renegotiation of existing arrangements; and
- that transfer, termination or substantial renegotiation might be compensated between Independent Persons in comparable circumstances.

Moreover, in some Business Restructurings, the circumstances may be such that, rather than losing a “profit-making opportunity”, the restructured Person is actually being relieved from the likelihood of a “loss-making opportunity”. A Person may agree to a restructuring as a better option than going out of business altogether.

For example, a restructured Person is forecasting future losses without a restructuring (e.g. it operates a manufacturing plant that is uneconomic due to increasing competition from low-cost imports). In this case, there may be no 'loss of a' profit-making opportunity from a restructuring. However, the Business Restructuring may provide a benefit to the restructured Person from reducing or eliminating future losses (if the losses exceed any structuring costs).

Appendix 16 includes an example of the relocation of risk and profit potential.

9.4. Indemnification of the restructured Person

As a starting point to determine whether an indemnification of the restructured Person for the termination or renegotiations of existing arrangements is appropriate, the legal arrangements need to be assessed (e.g. are there termination clauses / is there a termination or notification period applicable). As a second step it needs to be determined whether the legal arrangements include conditions that reflect Arm's Length circumstances.

Terminations or renegotiations of arrangements generally involve changes in the risk and functional profiles of the Persons, which in turn affects the allocation of profit potential between them. In addition, the termination or renegotiation of contractual relationships in the context of a Business Restructuring might cause the restructured Person to suffer for example:

- restructuring costs (e.g. write-off of assets, termination of employment contracts);
- re-conversion costs (e.g. in order to adapt its existing operation to other customer needs); and/or
- a loss of profit potential.

In these situations, the question arises of whether, at Arm's Length, indemnification should be paid to the restructured Person, and if so, how to determine such an indemnification. Note that it should not be presumed that contract terminations or substantial renegotiation give a right to an indemnification on an Arm's Length basis in all cases. This will depend on the facts and circumstances on each individual case.

Once the restructuring arrangements have been accurately determined and the options realistically available to the Persons have been assessed, the following aspects should be considered:

- Whether commercial law supports rights to indemnification for the restructured Person under the facts of the case as accurately isolated.
- Whether the existence or absence of an indemnification clause or similar provisions (as well as the terms of such a clause, if it exists) under the terms of the arrangement, as accurately isolated, is Arm's Length.
- The Person who should ultimately bear the costs related to the indemnification of the Person that suffers from the termination or renegotiation.

To determine the indemnification upon a Business Restructuring the comparison of the pre-Business Restructuring and post-Business Restructuring functions performed, risks assumed, and assets used is important to see how the profit potential is impacted. In view of this further Guidance is included in Chapters 10 and 12.

10.

Valuation

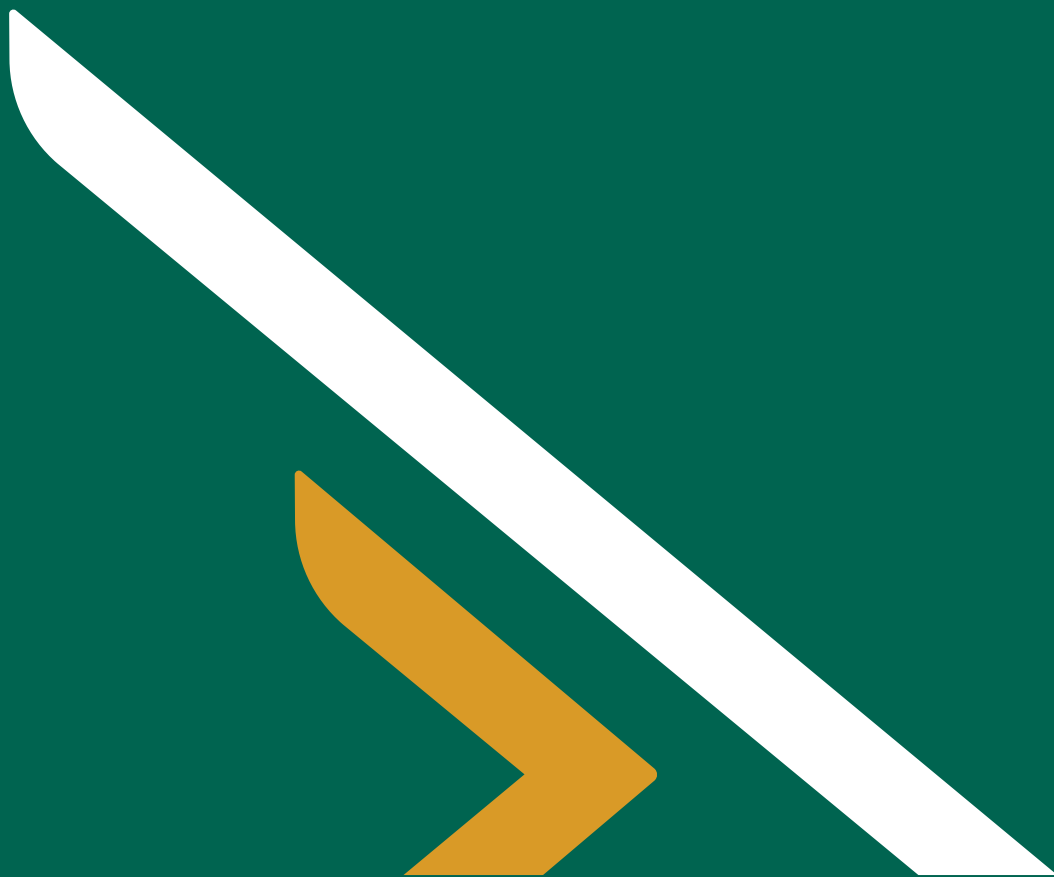

10. Valuation

This Chapter provides specific guidance on valuations. Specifically the following is included:

- It may be possible to use valuation techniques to estimate the Arm's Length Price for the determined Controlled Transaction. It is essential to carefully consider the assumptions and other motivations that underlie particular applications of valuation techniques.
- A fixed price agreed upfront will not be at Arm's Length if the valuation at the time of the Transaction is highly uncertain and Independent Persons acting in a commercially rational manner would not have agreed on a fixed price in a similar situation. In such cases, an adjustment clause might be included in the agreement between the Related Persons where the price is partly dependent on the future income.

10.1. Use of valuation techniques

In situations where reliable comparable Uncontrolled Transactions for a transfer of one or more Intangibles or in case of a Business Restructuring of a (part of a) business (which could involve both tangible and Intangible assets) cannot be identified, it may be possible to use valuation techniques to estimate the Arm's Length Price for the determined Controlled Transaction.

In particular, the use of income-based valuation techniques, and especially valuation techniques based on the calculation of the discounted value of projected future income streams or cash flow derived from the exploitation of the Intangible/transferred going concern, may be useful when properly applied. It is essential to carefully consider the assumptions and other motivations that underlie particular applications of valuation techniques.

Valuation techniques that estimate the discounted value of projected future cash flows derived from the exploitation of the transferred Intangible(s)/business can be particularly useful when properly applied. There are many variations of these valuation techniques.

In general terms, such techniques measure the value of an Intangible/a business by the estimated value of future cash flow it may generate over its expected remaining lifetime. The value can be calculated by discounting the expected future cash flows to present value. Under this approach valuation requires, among other things:

- defining realistic and reliable financial projections;
- growth rates;
- discount rates (e.g. Weighted Average Cost of Capital, "WACC");
- the useful life of Intangibles/tangible assets;
- the tax effects of the Transaction; and when appropriate
- consideration of terminal values.

The calculation of the discounted value of projected cash flows derived from the exploitation of the Intangible/business transferred should be evaluated from the perspectives of each party to the Transaction in arriving at an Arm's Length Price. The Arm's Length Price should fall somewhere within the range of present values derived, as evaluated from the perspectives of the transferor and the transferee. There may be a situation where, a range of values cannot be created for the transfer of assets or going concerns, as determined from the perspective of both sides (for instance, the seller would require a higher price compared to what the buyer is willing to pay). This may be an indication that a termination payment is required or the possibility that the Transaction should be disregarded.

It is important to recognize that the value estimates based on valuation techniques can be volatile and rely on various assumptions. Due to the importance of the underlying assumptions and valuation parameters, taxpayers (generally) and tax administrations using valuation techniques in determining Arm's Length Pricing for transferred Intangibles/going concerns, the valuation parameters and assumptions should be explicit and should substantiate the valuation techniques (including the reasonableness of such assumptions) when creating the valuation model.

These concerns, amongst others, are important in evaluating the reliability of the particular application of a valuation technique.

There may be situations where the entrepreneurial functions and associated Intangible assets of an acquired Related Person are transferred to another Related Person, and they are left with routine functions only (i.e. an example of a business restructuring on which Guidance is included in Chapter 9). In such cases, the Arm's Length Price of the transfer is sometimes determined by deducting the expected 'perpetual' cash flow of the routine

function (discounted using a discount factor based on this routine function) from the discounted expected total cash flow of the acquired Related Person if no transfer had taken place. When assessing an Arm's Length Price determined in this way, the Authority will generally take the view, especially if only one contract with a Related Person is left behind, that the expected cash flow of a routine function cannot be discounted as perpetual. This is because such functions can be replaced relatively easily in the market and, partly for that reason, contracts with such functions generally have a relatively short duration.

10.2. Price adjustment clause

As a starting point, any type of Transactions should be for the benefit of both parties involved in the Transaction. However, when transferring an asset, a going concern or a part thereof, it can be difficult to determine the value at the time of the transfer, because insufficient insight exists into the future benefits and risks. If Independent Persons in comparable circumstances would have agreed on the inclusion of a mechanism to address high uncertainty in valuing the asset or a business or a part thereof, the Authority might determine the pricing of a Transaction involving an asset (or rights in an asset) or a transfer of a business (or a part thereof) on the basis of such mechanism. Similarly, if Independent Persons in comparable circumstances would have considered subsequent events so fundamental that their occurrence would have led to a prospective renegotiation of the pricing of a Transaction, such events should also lead to a modification of the pricing of the Transaction between Related Persons.

A fixed price agreed upfront will not be at Arm's Length if the valuation at the time of the Transaction is highly uncertain such that Independent Persons acting in a commercially rational manner would not have agreed on a fixed price in a similar situation. In such cases, measure such and the inclusion of an adjustment clause should be included in the agreement between the Related Persons where the price is partly dependent on the future income.

11.

Permanent Establishments

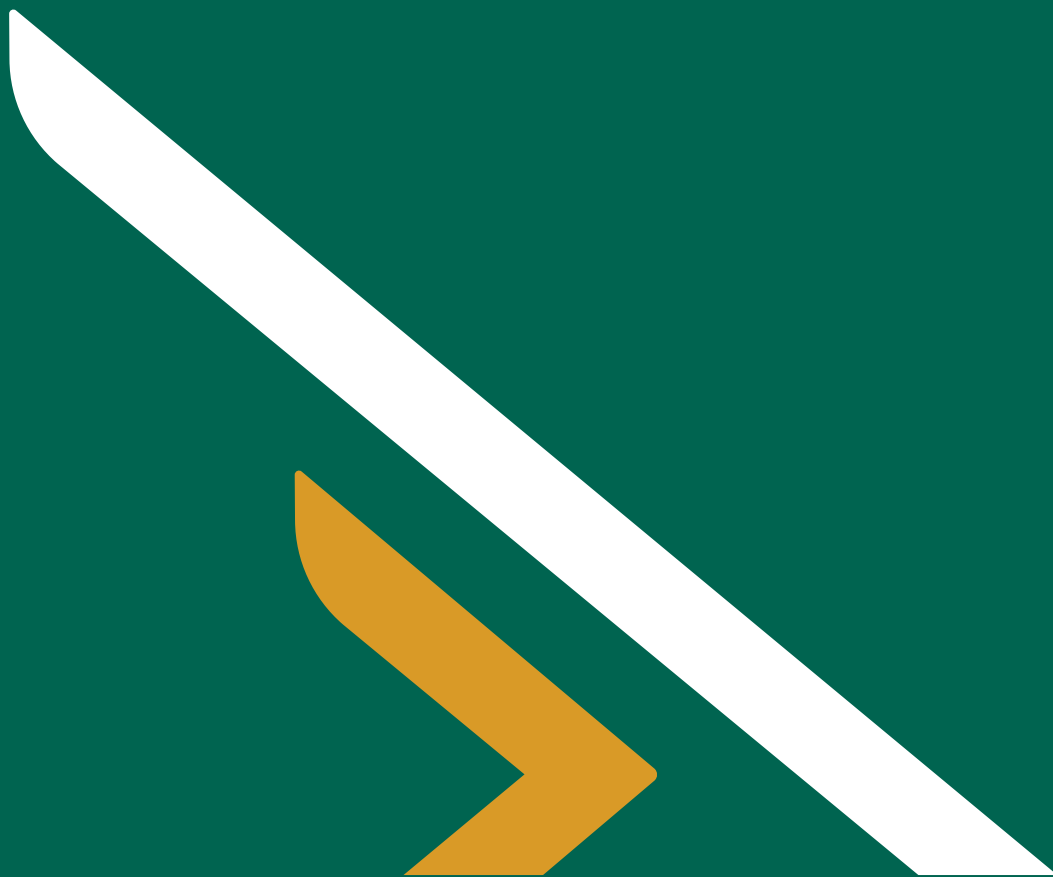

11. Permanent Establishments

This Chapter provides guidance on the implementation of the Arm's Length Principle on PEs.

- For the implementation of the Arm's Length Principle, members of the MNE Group (including PEs) are to be treated as separate entities that are operate independently rather than treated as inseparable from the MNE Group to which they belong. This is defined as the "Separate Entity Approach" or "SEA".

11.1. Application of the Arm's Length Principle to a Permanent Establishment

Under the SEA, the members of the multinational group are treated in a similar way as if they were operating as Independent Persons. In this approach, much attention is given to the nature of the Transaction between the Related Persons of the MNE and whether the conditions under which the Controlled Transaction takes place differs from the conditions that would have been obtained if the Transaction had taken place between Independent Persons.

In this respect, it is important to determine the Arm's Length Nature of the "Dealings" (i.e. similar to the Controlled Transactions between Related Persons) between the hypothetically separate PE and other parts of the Person to whom the PE belongs.

In general, it can be stated that profits attributed to a PE are the profits that the PE would have earned at Arm's Length, in particular in its Dealings with other parts of the Person, if it were a separate and independent Person engaged in the same or similar activities under the same or similar conditions, taking into account the functions performed, assets used and risks assumed by the Person through the PE and through the other parts of the Person.

A profit attribution between the Person and the PE of that Person requires a two-step analysis: first hypothesizing the PE as a distinct and separate person and secondly the determination of the profits of the PE based on a comparability analysis.

The first step begins with a Functional Analysis identifying the activities that are associated with the PE of the Person (as a separate Taxpayer) on the one side and with the Person or other foreign affiliates (as another separate Taxpayer) on the other side. In addition, the Functional Analysis should consider the assets used, and the risks assumed by the PE.

The PE should be considered as assuming any risk inherent in or created by the function conducted. Special consideration should be given to the identification of significant people functions. The “significant people functions approach” looks at the functions carried out by the people working for the Taxpayer and suggests allocating risks and assets in line with these functions as well as where the active decision-making with regard to the acceptance and/or management of risks is undertaken.

Under the second step and based on the result of the functional and risk analysis, the remuneration of any Dealings between the Person and the PE of that Person is determined by applying the Transfer Pricing Methods as outlined in Chapter 4 to evaluate the Arm’s Length Nature of the Dealings. In this respect, once the SEA has been applied, the ‘general’ Transfer Pricing steps should be performed to assess the Arm’s Length Nature of the Dealings.

12.

Audit and risk assessments

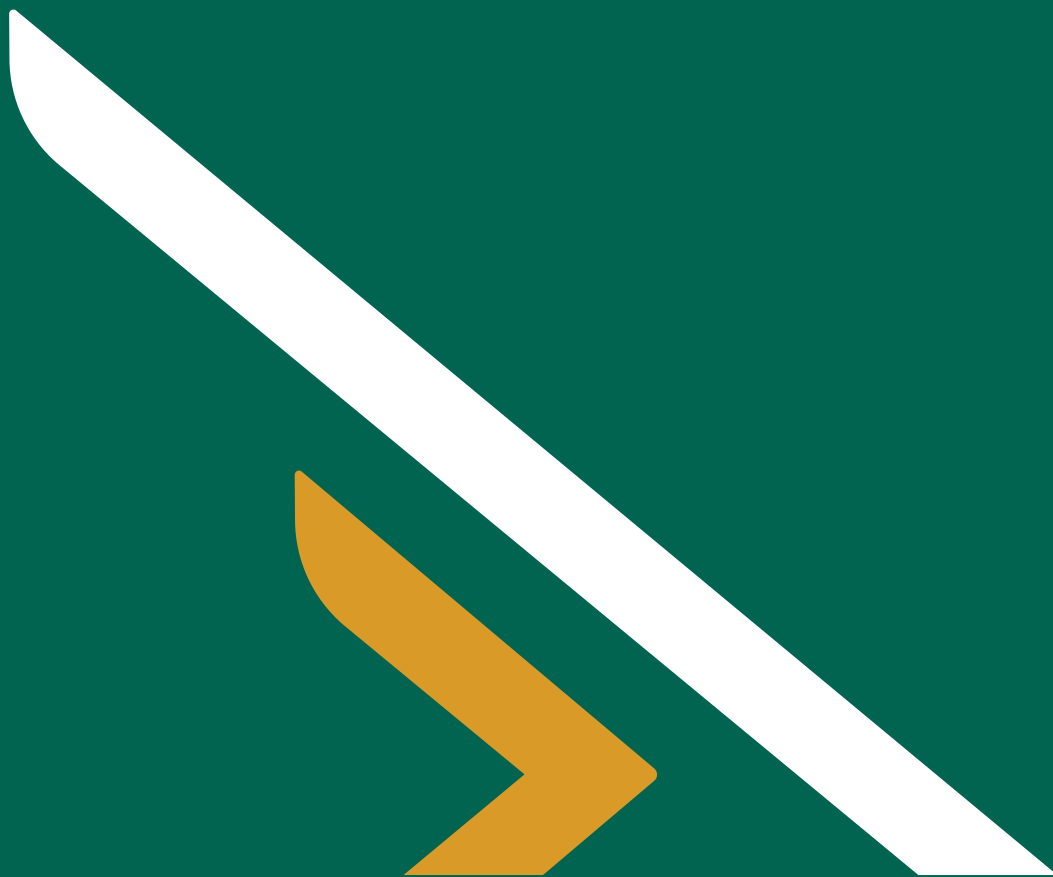

12. Audit and risk assessments

This Chapter provides guidance on Audit and risk assessments in the KSA.

- If the Taxpayers that are subject to the TP documentation requirements as outlined in this Guideline meet these requirements, this should in general lead to a defensible position with respect to the Controlled Transactions reported in the tax return.
- Based on Article 4 of the TP Bylaws, the Authority is able to adjust the Transactions between Related Persons that are not consistent with the Arm's Length Principle.

12.1. Burden of Proof

If the Taxpayers that are subject to the TP documentation requirements as outlined in this Guideline meet these requirements, in general this should lead to a defensible position with respect to the Controlled Transactions reported in the tax return. In case Taxpayer has not prepared the TP documentation in line with this Guideline, the burden of proof for the Taxpayer is increased. The Authority will assess to which extent the Taxpayer has provided sufficient information to meet the requirements under the increased burden of proof.

12.2 Transfer Pricing Adjustments

Based on Article 4 of the TP Bylaws, The Authority is able to adjust the Transactions between Related Persons that are not consistent with the Arm's Length Principle to reflect the results that would have been obtained by those Persons had they been acting at Arm's Length. The Taxpayer shall make adjustments to its tax base to include the returns it would have received if it was operating independently under similar conditions.

A price adjustment may only be imposed for tax purposes if the price of the Controlled Transaction deviates from the price that would have been established between Independent Persons under comparable circumstances. If the price or conditions of a standalone Controlled Transaction or a group of Transactions is adjusted, an analysis should be performed as to whether or not an Arm's Length profit is received by the Related Person after the adjustment has been applied, given the functions performed, the assets used and the risks assumed.

Next to this, in some cases the price or other conditions of other Controlled Transactions with other Group entities might have to be adjusted as well if they are not in accordance with the Arm's Length Principle. Thus, in exceptional situations - depending on the facts and circumstances - it should be assessed whether the price and/or conditions of the Controlled Transactions should be adjusted and which Related Persons would be subject to such an adjustment.

13.

Appendices

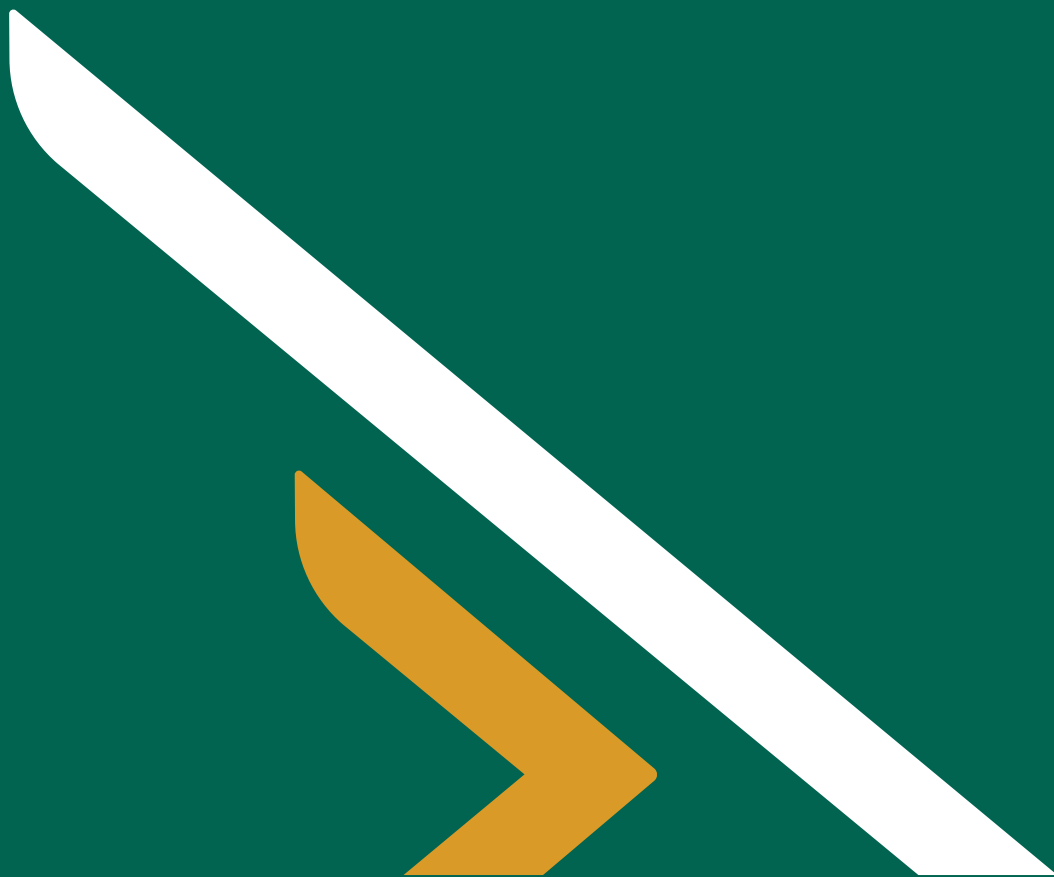

13. List of appendices

#	Name of Appendix
1	Example of joint venture with both KSA and Foreign shareholder
2	General example application Internal CUP
3	General example application External CUP
4	General example application Resale Price Method
5	General example application Cost Plus Method
6	General example application Transactional Net Margin Method
7	General example application Profit Split Model
8	Minimum requirement Master File
9	Minimum requirement Local File
10	Country-by-Country Reporting Model Template
11	Disclosure Form and Country by Country reporting Form – user manual
12	General example in relation to specific guidance on Intangibles (1)
13	General example in relation to specific guidance on Intangibles (2)
14	General example in relation to specific guidance on Intangibles (3)
15	General example in relation to specific guidance on Business Restructuring – Risk
16	General example in relation to specific guidance on Business Restructuring – Distributor

Appendix 1 - Example of Mixed Company with both Saudi and non-Saudi Shareholders

The Arm's Length Principle applies to both domestic and cross border Transactions. The Arm's Length Principle also applies to Juridical Persons established under the laws of the Kingdom owned by Saudi Persons (including Persons treated as Saudis for income tax purposes) and non-Saudi Persons (i.e. Mixed Companies) to the extent that the Mixed Company is subject to income tax in the Kingdom.

The diagram below depicts an example of the above-mentioned situation.

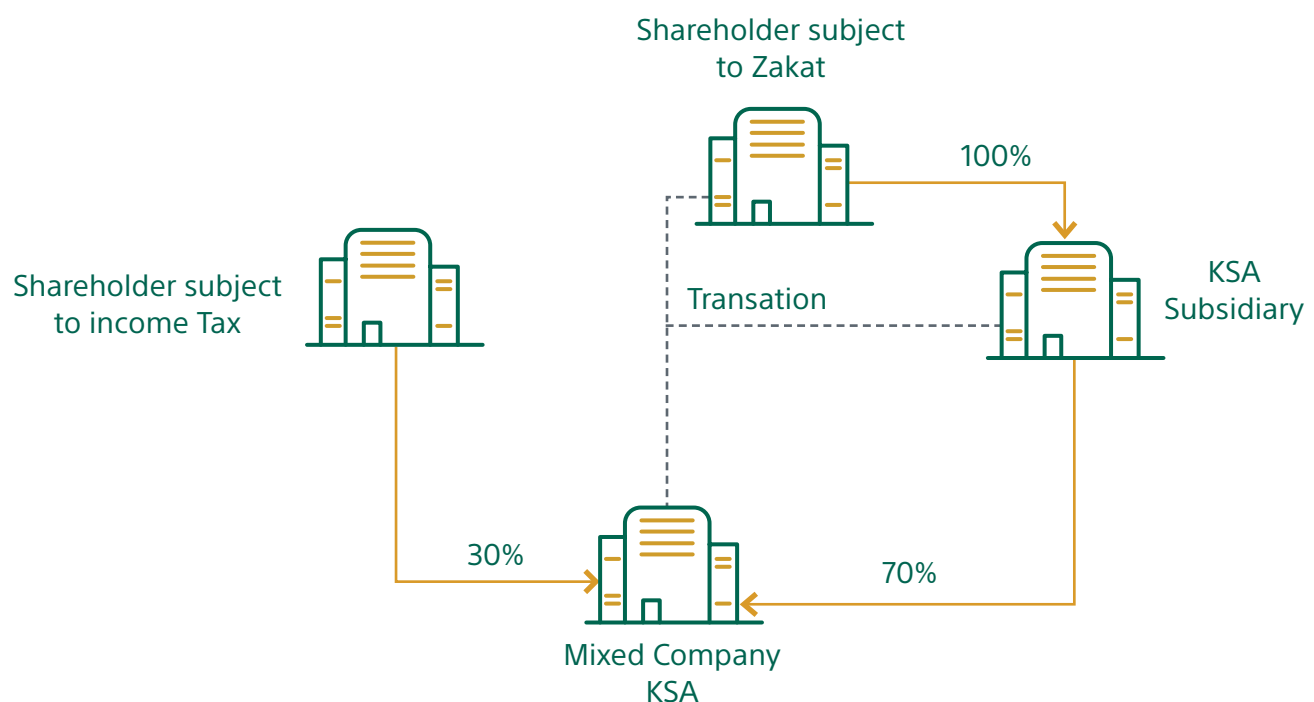

Figure 6 - Example of Mixed Companies

In the above-mentioned example the Arm's Length Principle also applies to the (Controlled) Transaction between KSA Subsidiary and the KSA Mixed Company to the extent that the KSA Mixed Company is subject to Income Tax. In this case, the tax base of the KSA Mixed Company is subject to Income Tax. In this case, the tax base of the KSA Mixed Company is 30% of its taxable income, due to its 30% foreign shareholding.

Appendix 2 - General example of application of the Internal CUP

The internal CUP may be applied for determining the Arm's Length Price of the Controlled Transaction.

- Company X and Company Y are Related Persons who form part of the same MNE
- Company X sells goods to Company Y at SAR 20 per unit.
- Additionally, Company X sells the same type of goods to Company Z (an Independent Person), however, Company Z receives a discount of 10% based on the quantity it buys (SAR 2 per product and SAR 18 is the discounted price).



Figure 7 - Examples of the Internal CUP

- In this particular case, the SAR 20 per unit charged for the sales of the product does not appear to satisfy the Arm's Length Principle. If possible, a comparability adjustment should be made.
- Where potentially Comparable Transactions are identified, but there are one or more differences that materially affect the price, comparability adjustments may be possible to neutralize this effect.
- Comparability adjustments may include the effect of quantity discounts, delivery terms, contractual terms, and minor product differences.
- Some differences may be impossible to account for by making adjustments, such as differences in geographical market, branding (trademarks) or valuable Intangibles, functional differences, and significant contractual differences.
- In this particular case, the Controlled Transaction can be adjusted based on the internal comparable, i.e. the price which Company X charges to Company Y should be SAR 18 instead of SAR 20 per unit. As a result, the profit of Company X will be lowered by $200,000 \text{ units} \times \text{SAR } 2 (\text{SAR } 20 - \text{SAR } 18) = \text{SAR } 400,000$.

Appendix 3 - General example of application of the external CUP

An external CUP might also be used for determining the Arm's Length Price of the Controlled Transaction.

- Company X and Company Y are Related Persons part of the same MNE.
- Company X sells goods to Company Y at SAR 20 per unit.
- Independent Persons enter into similar Transactions, which is the sale of a comparable good for SAR 18 per unit (which is the median result of the Arm's Length Range of multiple Comparable Uncontrolled Transactions identified). From the range of comparable transactions identified the upper quartile is lower than SAR 20 per unit.

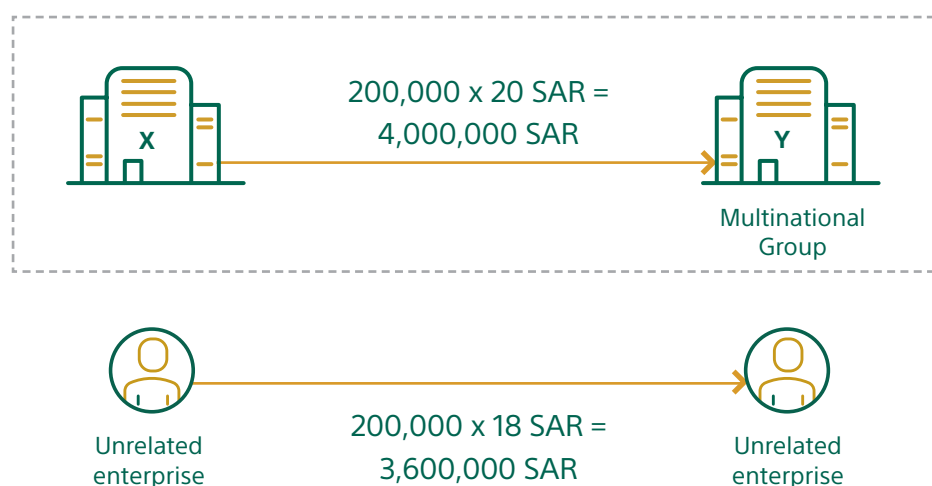

Figure 8 - Example of the External CUP

- It may be difficult to find an Uncontrolled Transaction between Independent Persons that is similar enough to a Controlled Transaction such that no differences have a material effect on price.
- Provided that the price between the Independent Persons is equal to the quoted price and that the economically relevant characteristics of the Controlled Transaction between Company X and Company Y and the Uncontrolled Transactions are comparable, the price set between the Independent Persons may be applied as the Arm's Length Price for the Transactions between Company X and Company Y.

- Where potentially Comparable Transactions are identified, but there are one or more differences that materially affect the price, comparability adjustments may be possible to neutralize this effect.
- Comparability adjustments may include the effect of quantity discounts, delivery terms, contractual terms, and minor product differences.
- Some differences may be impossible to account for by making adjustments, such as differences in geographical market, branding (trademarks) or valuable Intangibles, functional differences, and significant contractual differences.
- Comparability data of the Uncontrolled Transactions entered into by Independent Persons can be obtained from external databases, such as commodity exchanges, stock exchanges, customs, loan Transactions databases or royalty Transactions databases.
- In order to satisfy the Arm's Length Principle, a range of results from external databases would be required.
- In this particular case, the price charged for the sales of the product does not appear to satisfy the Arm's Length Principle. If possible, a comparability adjustment should be made.
- In this particular case, an adjustment would be justified since 20 is outside the Arm's Length Range (assuming the adjustment will be to the median point – further guidance is provided in Chapter 4 on the financial analysis). This adjustment reduces the price of the products purchased by Company Y from Company X. As a result, Company Y will pay a total price that is lower by SAR 400,000 (200,000 units * SAR 2 (SAR 20 – SAR 18) = SAR 400,000).

Appendix 4 - General example of application of the Resale Price Method

The following example describes how the RPM applies to a Transaction between Related Persons. Note that the example is purely for indicative purposes.

- Company X and Company Y are Related Persons and part of the same MNE.
- Company X sells goods to Company Y, whereby Company Y reports a gross margin of 25%.
- Company Y hereafter sells the goods to a customer in the market.
- The customer pays SAR 1,000 per unit to Company Y for the goods.
- The gross margin achieved by Company Y on the products bought from Company X amounts to $(\text{SAR } 1,000 / \text{SAR } 750) / \text{SAR } 1,000 = 25\%$ per unit
- Comparable Independent Persons buy the similar type of goods from Independent Persons. These Independent Comparable Persons subsequently sell the goods to customers in the market for gross margins varying from 27% – 17%. Therefore the applied gross margin of 25% is considered to be within the Arm's Length Range.

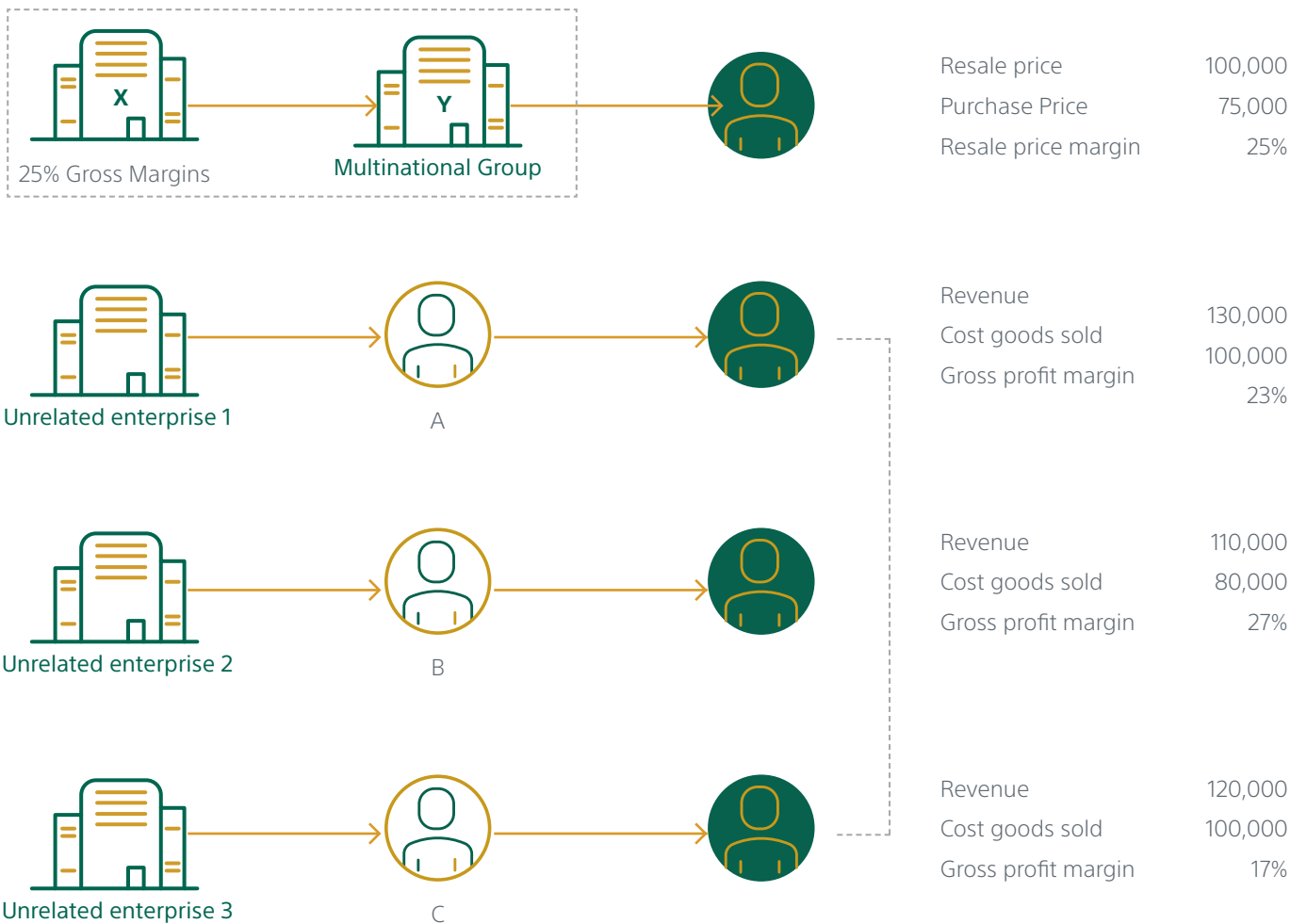

Figure 9 - Example of the Resale Price Method

Appendix 5 - General example of application of the Cost Plus Method

The following example describes how the C+ Method applies to a Transaction between Related Persons. Note that the example is purely for indicative purposes.

- Company X and Company Y are Related Persons and part of the same MNE.
- Company X manufactures goods and sells these to Company Y who is the IP owner and distributor of the products to customers. Company X is considered a “Contract Manufacturer”.
- The direct and indirect product costs incurred by Company X for the production of the semi-finished goods amounts to SAR 8,000,000.
- Comparable Independent Persons manufacture similar type of goods for Independent Persons. Based on a comparability analysis it is shown that these Persons perform similar functions as Company X. These Independent Comparable Persons apply cost plus mark-ups varying from 42% – 46%.
- The cost plus mark-up achieved by Company X of 40% does not fall within the Arm’s Length Range. Depending on the facts and circumstances comparability adjustments may be considered. If this is not possible, an adjustment to the median value of the range would be required (reflecting a margin of 44% instead of 40%).

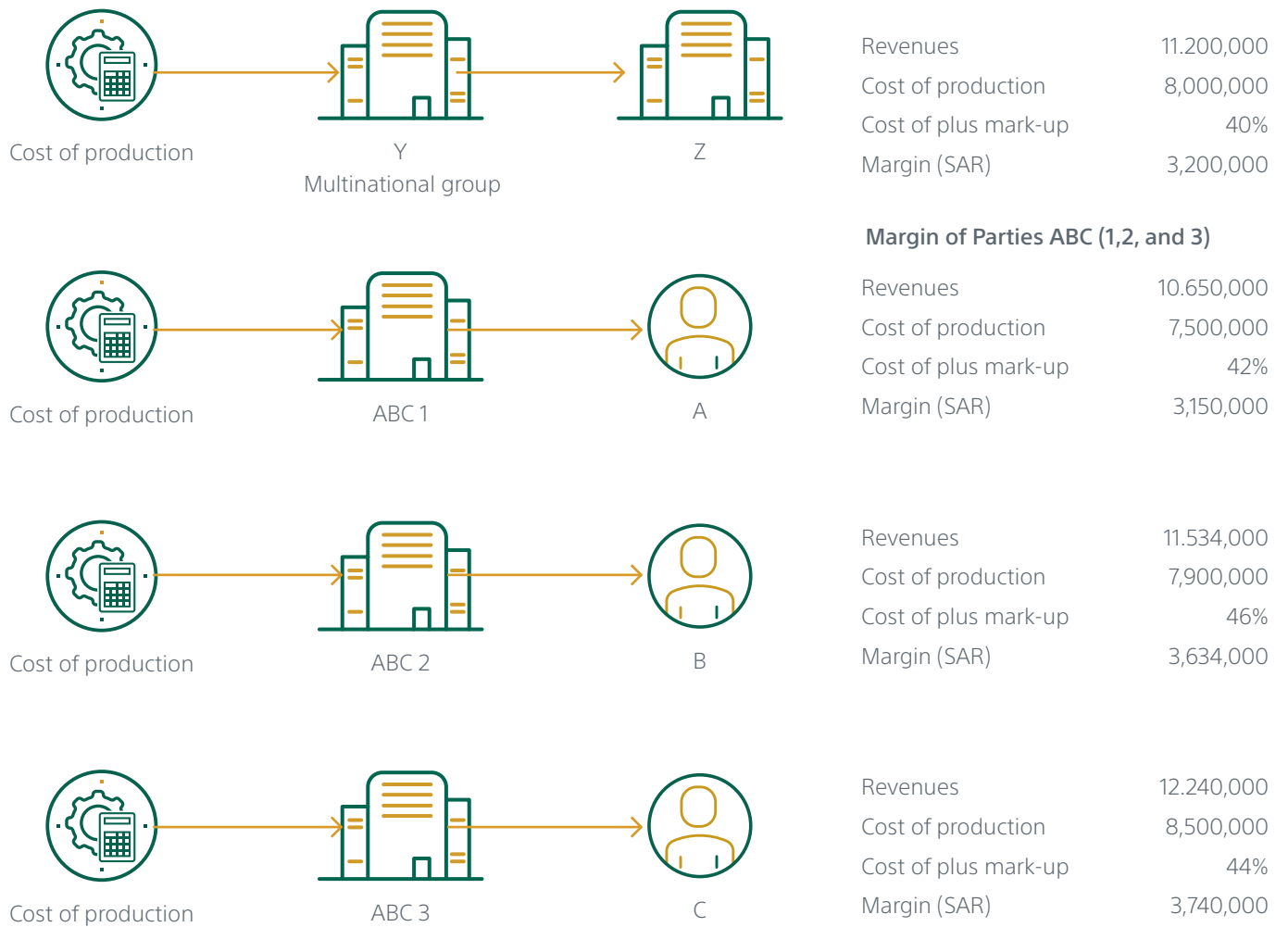

Figure 10 - Example of the Cost Plus Method

Appendix 6 - General example of application of the Transactional Net Margin Method

The following example describes how the TNMM applies to a Transaction between Related Persons. Note that the example is purely for indicative purposes.

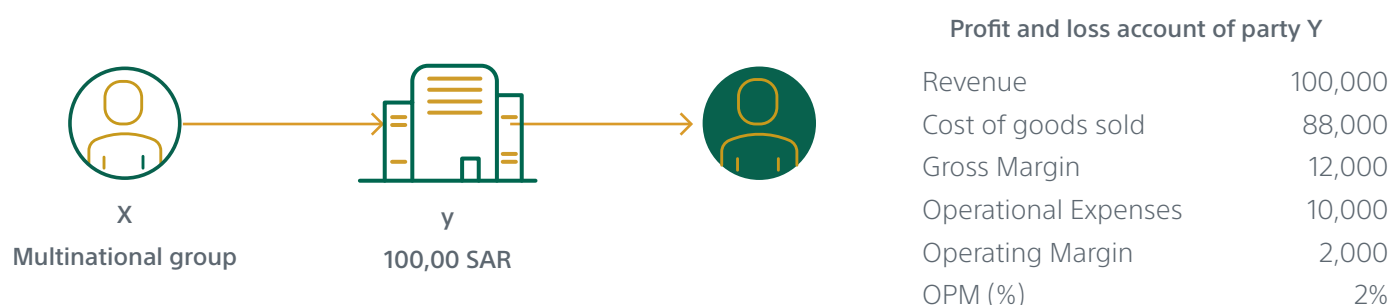

Figure 11 - Example of the Transactional Net Margin Method

- Company X and Company Y are Related Persons and part of the same MNE.
- Company X is the only supplier of goods to Company Y, Initially, the total amount of costs charged for the goods by Company X to Company Y amounts to 88,000.
- Company X manufactures goods for which it owns and uses valuable unique intangibles such as valuable patents and trademarks, and for which Company Y acts as a distributor and sells the final product to customers. Company Y only performs simple functions and does not make any valuable, unique contribution in relation to the transaction. Based on their functions and risks profile, Company Y would be the “least complex party” within the Controlled Transaction.
- Accordingly, the TNMM could be applied on the results of Company Y to evaluate whether the net profit received is considered to be at Arm’s Length. Considering the limited risk distribution activities performed by Company Y, the OPM/ROS is considered most appropriate as the PLI.
- The annual net revenue reported by Company Y amounts to SAR 100,000 and the operational expenses to SAR 10,000. Eventually, this would have resulted in an operating margin of SAR 2,000 (i.e. Revenue of SAR 100,000 – Cost of Goods Sold of SAR 88,000 – Operational expenses of SAR 10,000 = operating margin (EBIT) of SAR 2,000). The diagram above gives an overview of the profit and loss account of Company Y:

- Based on a benchmark study performed on the available data on independent distributors who sell similar goods, the net operating margin in the inter-quartile range is between 4% and 6% with the median being 5%.
- In the example, the actual net operating margin achieved amounts to $(\text{SAR } 2,000 / \text{SAR } 100,000) * 100\% = 2\%$. Conclusively, it could be considered that the remuneration received for the distribution function performed by Company Y is not at Arm's Length considering the remuneration received by independent distributors.
- If it is determined that the median of the benchmark study would result in an appropriate Arm's Length remuneration for distribution activities performed by Company Y, the total amount of net OPM reported should be $\text{SAR } 100,000 * 5\% = \text{SAR } 5,000$. Thus, the operation profit should be SAR 3,000 higher compared to the current situation.
- This could be achieved by adjusting the current cost of goods sold incurred by the Related Person (i.e. Company X) to ensure that the 5% operating margin is achieved. The difference in cost of goods sold would amount to $\text{SAR } 5,000 - \text{SAR } 2,000 = \text{SAR } 3,000$.

Appendix 7 - General example of application of the Residual Profit Split Method

The following example describes how the PSM applies to a Transaction between Related Persons. Note that the example is purely for indicative purposes.

- The success of a product is linked to the innovative technological design both of its electronic processes and of its major component.
- Company X, Company Y and Company Z are Related Persons and part of the same MNE.
- Company X designs and manufactures a component. Thereafter, the product is shipped to Company Y
- Company Y designs and manufactures the rest of the product.
- Company Z distributes the product. This example assumes that Company Z is being appropriately rewarded by the Transfer Price of the finished product from Company Y to Company Z. The amount of residual profit accrued by Company X and Company Y from the exploitation of the Intangible should be further analysed.

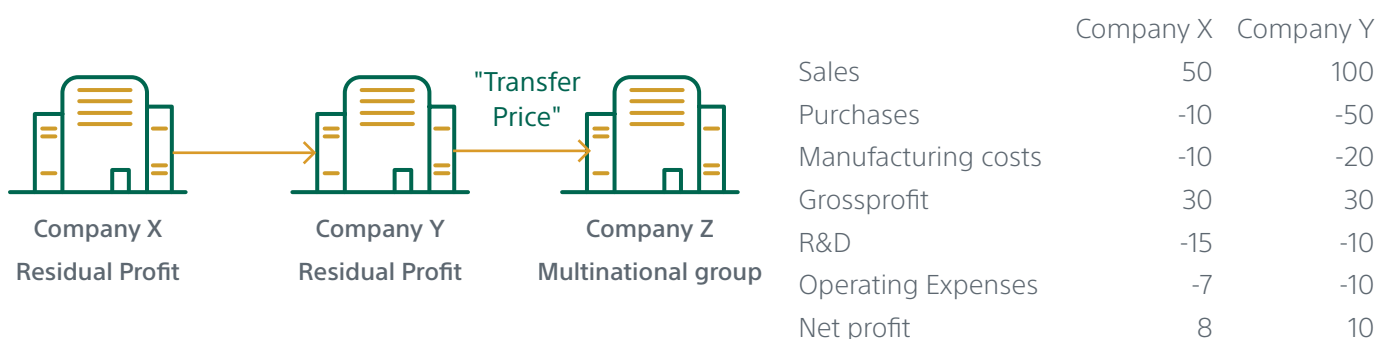

Figure 12 - Example of the Profit Split Method

- The R&D activity of each Person is directed towards technological design relating to the same class of item, and it is established for the purposes of this example that the relative amounts of R&D expenditure reliably measure the relative value of the companies' contributions (i.e. each Person's contribution to the product's technological innovation may reliably be measured by their relative expenditure on R&D)
- The R&D activity of each Person is directed towards technological design for the same class of item and the relative amounts of R&D expenditure are considered to be a reliable

measure for their contribution. Assuming Company X's R&D expenditure is 15 and Company Y's is 10 the residual could be split 3/5 for Company X and 2/5 for Company Y. See the Profit & Loss accounts for both Persons before the application of the Residual Profit Split.

- As a next step, it is determined that for both jurisdictions independent comparable manufacturers without innovative intangible property earn a return on manufacturing costs of 10% (i.e. Company X Co. $10.0 * 10\% = 1.0$ and Company Y $20.0 * 10\% = 2.0$).
- To determine the residual profit the manufacturing profit is deducted from the combined net profit of Company X and Company Y): $18.0 - 1.0 - 2.0 = 15.0$.
- The initial allocation of profit 1.0 to Company X and 2.0 to Company Y does not recognize the value of the R&D that has resulted in the technological advanced product. The residual profit can be appropriately split between Company X and Company Y based on their share of total R&D costs as this accurately reflects their relative contribution in value. Company X.'s share is $15 * (15 / 25) = 9.0$ and Company Y's share is $15 * (10 / 25) = 6.0$. This is reflected by an increase in the sales price from Company X to Company Y by 2.0 (from 50 to 52).
- Company X's net profits would thus become $1.0 + 9.0 = 10.0$.
- Company Y's net profits would thus become $2.0 + 6.0 = 8.0$.

See the revised Profit & Loss accounts for both Persons below:

	Company X	Company Y
Sales	52	100
Purchases	-10	-52
Manufacturing costs	-10	-20
Grossprofit	32	28
R&D	-15	-10
Operating Expenses	-7	-10
Net profit	10	8

Figure 13 - Example of Adjusted Profit and Loss Account

In view of the above, it should be noted that the allocation of the Residual Profit Split may need considerable refinement in practice in order to identify, quantify and substantiate the appropriate basis for the allocation. Where R&D expenditure is used, differences in the types of R&D conducted may need to be taken into account, e.g. because different types of R&D may have different levels of risk associated with them, which would lead to different levels of expected returns at Arm's Length. Relative levels of current R&D expenditure also may not adequately reflect the contribution to the earning of current profits that is attributable to Intangible property developed or acquired in the past.

Appendix 8 - Minimum requirements of the Master File

1. Organizational structure, illustrating the Multinational Enterprise's legal and beneficial ownership structure, and geographical location of operating entities.
2. Description of Multinational Enterprise Group's business, i.e. general written description of the Multinational Enterprise Group's business, including:
 - Important drivers of business profit;
 - a description of the supply chain for the Multinational Enterprise Group's largest products and service offerings by turnover plus any other products and services amounting to more than 5% of group turnover;
 - a list and brief description of important service arrangements between Multinational Enterprise Group members other than research and development services, including a description of the capabilities of the principal locations providing important services and transfer pricing policies for allocation of the costs of services and determining prices to be paid for intra-group services;
 - a description of the main geographical markets for the group's products and services;
 - a brief written Functional Analysis describing the principal contributions to value creation by individual entities within the group, i.e. functions performed, important assets used, and important risks assumed; and
 - a description of important business restructuring Transactions, acquisitions, and divestitures occurring during the fiscal year.
3. Information on the Multinational Enterprise Group's Intangibles, including:
 - A general description of the Multinational Enterprise Group's overall strategy for the development, ownership and exploitation of Intangibles, including location of principal research and development facilities and of research and development management;
 - a list of Intangibles or groups of Intangibles, including which entities are the legal owner of these Intangibles, of the Multinational Enterprise Group that are important for transfer pricing purposes;
 - a list of important agreements among identified related parties concerning Intangibles, including cost contribution arrangements, principal research service agreements and license agreements;

- a general description of the group's transfer pricing policies related to research, development and Intangibles; and
 - a general description of any important transfers of interests in Intangibles among Related Persons during the fiscal year concerned, including the entities, countries, and compensation involved.
- 4. Information on the Multinational Enterprise Group's intercompany financial activities, including:**
- a general description of how the group is financed, including material financing arrangements with independent lenders;
 - the identification of any members of the Multinational Enterprise Group that provide a central financing function for the group, including the country under whose laws the entity is organized and the place of effective management of such entities; and
 - a general description of Multinational Enterprise Group's transfer pricing policies related to financing arrangements between Related Persons.
- 5. Information on the Multinational Enterprise Group's financial and tax positions, including:**
- The Multinational Enterprise Group's annual consolidated financial statement for the fiscal year concerned if otherwise prepared for financial reporting, regulatory, internal management, tax or other purpose; and
 - a list and brief description of the Multinational Enterprise Group's existing unilateral Advance Pricing Agreements and other tax rulings relating to the allocation of income among countries.

Appendix 9 - Minimum requirements of the Local File

1. Taxable Person's information, including:
 - A description of the management structure of the Taxable Person, its organization chart, a description of the individuals to whom the Taxable Person's management reports and the countries in which such individuals maintain their principal offices;
 - a detailed description of the business and business strategy pursued by the Taxable Person including an indication whether the Taxable Person has been involved in or affected by business restructurings or transfer of Intangibles property, in the present or immediately prior year, and an elaboration on the aspects of such Transactions that affect the local entity; and
 - key competitors.
2. Documentation on material Controlled Transactions. For Controlled Transactions in which the Taxable Person is involved generally, the following information should be included:
 - A description of the Controlled Transactions (e.g. procurement of manufacturing services, purchase of goods, provision of services, loans, financial and performance guarantees, licenses of Intangibles, etc.) and the context in which such Transactions take place;
 - the amount of intra-group payments and receipts for each category of Controlled Transactions involving the Taxable Person (e.g. payments and receipts for products, services, royalties, interest, etc.) broken down by country of tax residence the foreign payer or recipient;
 - an identification of Related Persons involved in each category of Controlled Transactions, and the relationships amongst them;
 - Copies of all intercompany agreements concluded by the Taxable Person;
 - a detailed comparability and Functional Analysis of the Taxable Person and relevant Related Persons with respect to each documented category of Controlled Transactions, including any changes compared to prior years;
 - an indication of the most appropriate transfer pricing method with regard to the category of Transaction and the reasons for selecting that method;
 - an indication of which related Person is selected as the tested party, if applicable, and an explanation of the reasons for this selection;

- summary of the important assumptions made in applying the transfer pricing methodology;
 - if relevant, an explanation of the reasons for performing a multi-year analysis;
 - a list and description of selected comparable Uncontrolled Transactions (internal or external), if any, and information on relevant financial indicators for independent enterprises relied on in the transfer pricing analysis, including a description of the comparable search methodology and the source of such information;
 - a description of any comparability adjustments performed, and an indication of whether adjustments have been made to the results of the tested party, the comparable Uncontrolled Transactions, or both;
 - a description of the reasons for concluding the relevant Transactions were priced on an arm's length basis based on the application of the selected transfer pricing method;
 - a summary of financial information used in applying the transfer pricing methodology; and
 - a copy of existing unilateral and bilateral/multilateral Advance Pricing Agreements and other tax rulings to which The Authority is not a party, and which are related to Controlled Transactions described above.
3. Industry analysis which provides complete and thorough analysis of the Taxable Person's industry, including but not limited to:
- major competitors;
 - Strength, Weakness, Opportunity and Threat analysis;
 - power of suppliers;
 - power of buyers;
 - availability of substitutes;
 - size;
 - demand and supply trends;
 - entry requirements;
 - key international target markets;
 - market share; and
 - modes of delivery.

4. Financial information, including:

- Annual financial statements for the fiscal year concerned of the Taxable Person. If audited financial statements exist, these should be supplied and if not, existing unaudited financial statements should be supplied;
- Information and allocation schedules showing how the financial data used in applying the transfer pricing method may be referenced to the annual financial statements; and
- Summary of schedules of relevant financial data for comparables used in the analysis and the sources from which that data was obtained.

Appendix 10 - Country-by-Country Reporting Model Template

Table (1)										
Name of the MNE Group:										
Reporting Year:										
MNE Group's Functional Currency used:										
Tax Jurisdiction	Revenues			Profit (Loss) before Income Tax	Income Tax Paid (on Cash Basis)	Income Tax Accrued - Current Year	Stated Capital	Accumulated Earnings	Number of Employees	Tangible Assets other than Cash and Cash Equivalents
	Unrelated Person	Related Person	Total							

Table (2)

**Name of the MNE Group:
Reporting Year concerned:**

Tax Jurisdiction	Constituent Entities Resident in the Tax Jurisdiction (including Tax identification number and address)	Tax Jurisdiction of Organization or Incorporation if different from the Tax Jurisdiction of Residence	Main Business (Activities)																					
			Research and Development	Holding or Managing Intellectual Property	Purchasing or Procurement	Manufacturing or Production	Sales, Marketing or Distribution	Administrative, Management or Supportive Services	Provision of Services to Unrelated Persons	Internal Group Finance	Regulated Financial Services	Insurance	Holding Shares or Other Equity Instruments	Dormant	Other									

Table (3)

1	Name of the MNE Group:	
	Reporting Year Concerned:	
2	Please include additional (brief) information or explanations considered to be necessary necessary or helpful to understand the reported information provided in the Country-by-Country Report.	

Appendix 11 - Transfer Pricing and CbCR Form (user manual)

1. Click on **Yes** radio button to complete **Transfer Pricing** form

2. On step 1 of **Transfer Pricing** section Taxpayer must select **Transactions** dropdown enter **Description, Name of Related Party, Jurisdiction** dropdown, **Revenue, Expense and TP method** dropdown. In sub section b Taxpayer must select **yes/no** radio button as displayed below. In sub section C Taxpayer must provide information like **Total revenue, Total Expense and Net profit/loss**.

1. Do you have any related party transaction? Yes No

a. Please provide all related party transactions details:

Transactions	Description	Name of Related Party	Jurisdiction	Transaction Nature	Amount	TP Method
<input type="text"/>	<input type="text"/>	<input type="text"/>	<input type="text"/>	<input type="text"/>	<input type="text"/>	<input type="text"/>

b. Have you or the group gone through business restructuring during the current tax filing year?
 Yes No

c. Please provide the following information in accordance with your Tax return declaration:

Total Revenue (SAR)	Total Expense (SAR)	Net Profit / (Loss) (SAR)
<input type="text"/>	<input type="text"/>	<input type="text"/>

d. Has Transfer Pricing (TP) documentation been maintained in line with the KSA Transfer Pricing bylaws?
 Yes No Not Applicable

e. Has the company conducted non-monetary/free of charge transactions with related parties?
 Yes No

f. Please provide all shareholder's details as described below:

Name of Shareholder	Jurisdiction	Ownership Percentage (%)
<input type="text"/>	<input type="text"/>	<input type="text"/>

2. Are you part of MNE-group that qualifies for country by country reporting?(You will need to say Yes if the group turnover is in excess of SAR 3.2 billion)
 Yes No

3. In sub section d the Taxpayer has three options to select **Yes/No/not applicable**. If the Taxpayer selects the “Yes” radio button, two checkboxes will be displayed, **Local File** and **Master File** which are mandatory. In sub section e taxpayer will select **Yes/No** radio button as displayed below. Further, the Taxpayer must enter **Transaction Description**, **counterparty** field and select Jurisdiction dropdown. Taxpayer also has an option to add and delete the row. In sub section f Taxpayer must provide all the shareholder details like **Name of Shareholder**, **Jurisdiction** and **Ownership percentage**.

The screenshot shows the 'ZAKAT Return' form with the following sections:

- a. Please provide all related party transactions details:** A table with columns: Transactions, Description, Name of Related Party, Jurisdiction, Transaction Nature, Amount, TP Method.
- b. Have you or the group gone through business restructuring during the current tax filing year?** Radio buttons for Yes/No.
- c. Please provide the following information in accordance with your Tax return declaration:** Fields for Total Revenue (SAR), Total Expense (SAR), and Net Profit / (Loss) (SAR).
- d. Has Transfer Pricing (TP) documentation been maintained in line with the KSA Transfer Pricing bylaws?** Radio buttons for Yes/No/Not Applicable. Checkboxes for Local File and Master File.
- e. Has the company conducted non-monetary/free of charge transactions with related parties?** Radio buttons for Yes/No. A table with columns: Transaction Description, Counter Party, Jurisdiction.
- f. Please provide all shareholder's details as described below:** A table with columns: Name of Shareholder, Jurisdiction, Ownership Percentage (%).

4. On section 2 the Taxpayer must click on **yes** radio button. After clicking on **yes** radio button taxpayer have to complete the legal name of **Ultimate Parent Entity**, **Identification Number (TIN)** for UPE, **tax Jurisdiction of the UPE** and **Financial year end of the UPE**.

The screenshot shows the 'ZAKAT Return' form with the following sections:

- 2. Are you part of MNE-group that qualifies for country by country reporting?(You will need to say Yes if the group turnover is in excess of SAR 3.2 billion)** Radio buttons for Yes/No.
- a. What is the Legal name of the Ultimate Parent Entity(UPE)?** Text input field.
- b. What is the tax identification number (TIN) for Ultimate parent entity(UPE)?** Text input field.
- c. Tax Jurisdiction of the UPE** Dropdown menu.
- d. Financial year end of the UPE** Date picker (YYYYMMDD).
- e. Legal name of the filing entity** Text input field.
- f. What is tax identification number(TIN) for the filing entity?** Text input field.
- g. Jurisdiction of the filing CoC Report** Dropdown menu.
- h. Financial year end of the filing entity** Date picker (YYYYMMDD).

5. In step 2, the Taxpayer must complete the **legal name of the filing entity, tax identification number (TIN) for the filing entity, Jurisdiction of the filing CbC Report and financial year end of the filing entity.** After completing all the mandatory details click on **Review** button.

The screenshot shows the 'Transfer pricing' step of the ZAKAT Return form. The form includes the following fields:

- 2. Are you part of MNE-group that qualifies for country by country reporting? (You will need to say Yes if the group turnover is in excess of SAR 3.2 billion)
- a. What is the Legal name of the Ultimate Parent Entity (UPE)?
- b. What is the tax identification number (TIN) for Ultimate parent entity (UPE)?
- c. Tax Jurisdiction of the UPE
- d. Financial year end of the UPE
- e. Legal name of the filing entity
- f. What is tax identification number (TIN) for the filing entity?
- g. Jurisdiction of the filing CbC Report
- h. Financial year end of the filing entity

A 'Review' button is located at the bottom left of the form.

6. Below screen will be displayed. Click on **Attach Chartered Accountant Certification** and **upload Copy of Financial Statement.** Attach the attachment in **Upload Copy of Financial Statement.**

The screenshot shows the 'Income' section of the ZAKAT Return form. The form includes the following items:

- Income
- Cost of Expense
- Amendments to the Net Profit/Loss Book
- Additional and Deductions to Zakat Pool
- Assets
- Liability & Equity
- Do you have any related party transaction ?
- Are you part of MNE-group that qualifies for country by country reporting? (You will need to say Yes if the group turnover is in excess of SAR 3.2 billion)

At the bottom of the form, there are three buttons: 'Attach Chartered Accountant Certification', 'Download Form', and 'Upload Copy of Financial Statement'. Below these buttons is a checkbox with the text: 'I declare that the above information is correct and I am responsible for it'.

Appendix 12 - General example in relation to specific guidance on Intangibles (1)

The following general example gives specific guidance on Intangibles. Note that the example is purely for indicative purposes.

- A MNE comprised of Company A and Company B. decides to develop an Intangible asset ("IP"). Company A and Company B are established and Taxable Persons in different countries.

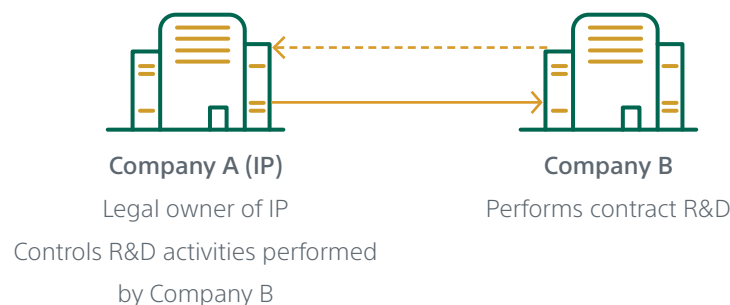

Figure 14 - Example of Intangibles development

- Legal rights and contractual arrangements form the starting point for any Transfer Pricing analysis of Transactions involving Intangibles. Under the development agreement between The Company A and The Company B:
 - o Company B will perform R&D activities related to the Intangible under management and control of The Company A
 - o Company A controls all activities related to the Development, Enhancement, Maintenance, Protection and Exploitation ("DEMPE") of the Intangible.
 - o Company A compensates Company B's R&D costs occurred including an Arm's Length mark-up. Company A also has the capacity and control over the funding of the development process.
 - o Company A will become the legal owner of the Intangible.
- A Functional Analysis of the arrangement assesses the functions performed, assets used and contributed, and risks assumed by Company A and by Company B The analysis through which the actual Transaction is isolated concludes that:
 - o Although Company B is performing activities related to the development, enhancement

and maintenance of the patent, its contribution to the arrangement is solely the provision of routine R&D for the development of the Intangible and assumes no relevant risks, but acts solely as a routine R&D entity.

o Company A controls the activities related to the DEMPE of the Intangible, and assumes all the economically significant risks.

- It is not essential that the legal owner (Company A) physically performs all of the functions related to the DEMPE of the Intangibles. Company A is able to outsource certain functions to Company B.
- Taking into account Company B's contributions, Company B should be compensated on an Arm's Length basis for the functions it performs, the assets it contributes and the risks it assumes. In this particular case, this is determined to be a 5% Net Cost Plus mark-up.
- Any future result from the developed IP is in principle attributable to Company A as it has both the legal ownership and control over the DEMPE functions. The fact that it did not physically perform all the functions itself is not essential as Company B is appropriately remunerated for the functions it carries out.

Appendix 13 - General example in relation to specific guidance on Intangibles (2)

The following general example gives specific guidance on Intangibles. Note that the example is purely for indicative purposes.

- In Year 1, a MNE comprised of Company A and Company B decides to develop an Intangible asset (IP), which is anticipated to be highly profitable based on Company B's existing intangibles, its track record and its experienced R&D staff. Company A and Company B are established and Taxable Persons in different countries.
- The Intangible is expected to take five years to develop before possible commercial exploitation.
- If successfully developed, the Intangible is anticipated to have value for ten years after initial exploitation.
- Under the development agreement between Company A and Company B:
 - Company B will perform and control all activities related to the Development, Enhancement, Maintenance, Protection and Exploitation ("DEMPE") of the Intangible.
 - Company A will provide all funding associated with the development of the Intangible (the development costs are anticipated to be SAR 400 million per year for five years), and will become the legal owner of the Intangible. Company A has the capability and capacity to provide the funding.

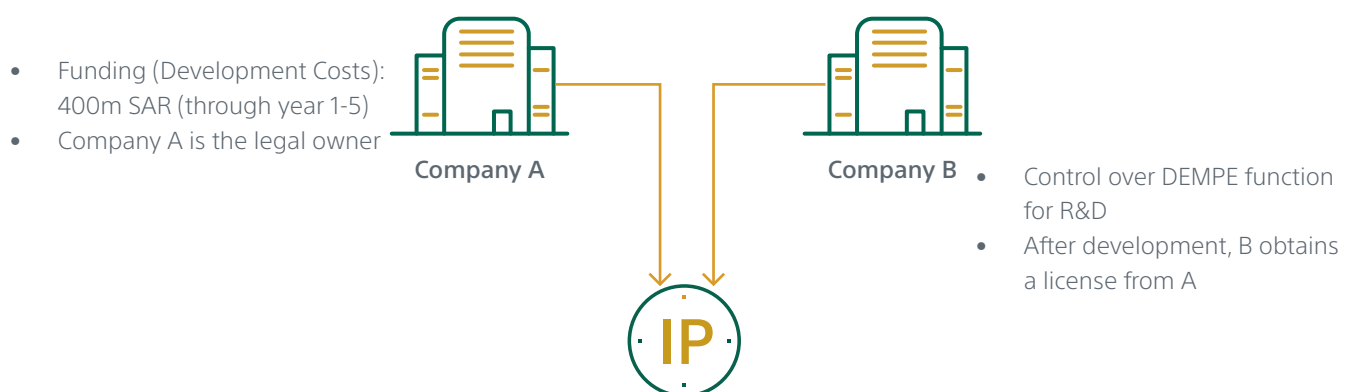

Figure 15 - Example of Intangibles development

- Once developed, the Intangible is anticipated to result in profits of SAR 2,200 million per year (over a period of ten years from years 6 to 15).

- Company B will license the Intangible from Company A and make contingent payments to Company A for the right to use the Intangible, based on returns of comparable licensees.
- After the projected contingent payments, Company B will be left with an anticipated return of SAR 1,400 million per year from selling products based on the Intangible.

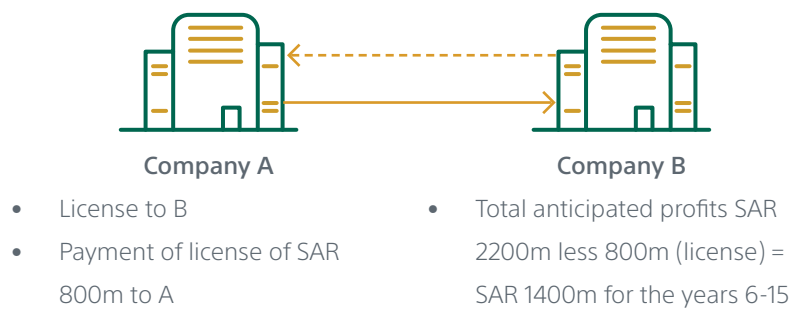

Figure 16 - Example of Intangibles returns

- A Functional Analysis by the local tax administration of Company B's country the arrangement assesses the functions performed, assets used and contributed, and risks assumed by Company A and by Company B. The analysis through which the actual Transaction is isolated concludes that:
 - o Although Company A is the legal owner of the Intangibles, its contribution to the arrangement is solely the provision of funding for the development of an Intangible.
- This analysis shows that Company A contractually assumes the financial risk, has the financial capacity to assume that risk, and exercises control over that risk.
- Taking into account Company A contributions, as well as the realistic alternatives of Company A and Company B, it is determined that Company A's anticipated remuneration should be a risk adjusted return on its funding commitment.
- In this example, this is determined to be SAR 440 million per year (for Years 6 to 15), which equates to an 11% risk-adjusted anticipated financial return.
- Company B, accordingly, would be entitled to all remaining anticipated income after accounting for Company A's anticipated return, or SAR 1,760 million per year (SAR 2,200 million minus SAR 440 million), rather than SAR 1,400 million per year as claimed by the Taxpayer. (Based on the detailed Functional Analysis and application of the most appropriate Method, the taxpayer incorrectly chose Company B as the "Tested Party" rather than Company A).

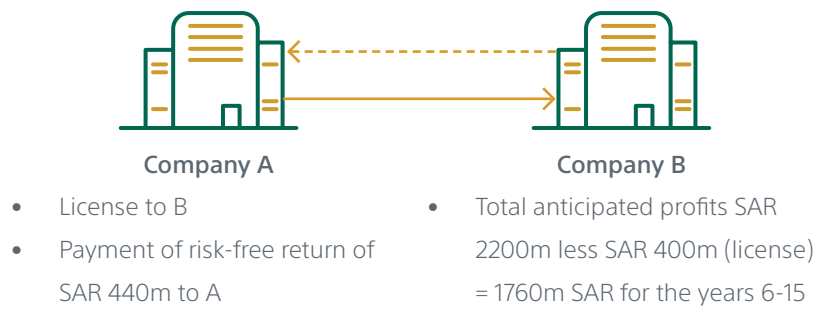

Figure 17 - Example of Intangibles returns

Appendix 14 - General example in relation to specific guidance on Intangibles (3)

The following general example gives specific guidance on Intangibles. Note that the example is purely for indicative purposes.

- Company A acquires 100% of the equity interests in an Independent Person, Company Z for SAR 100 million.
- Company Z is a Person that engages in R&D and has partially developed several promising technologies but has only minimal sales.
- The purchase price is justified primarily by the value of the promising, but only partly developed, technologies and by the potential of Company Z personnel to develop further new technologies in the future.
- Company A's purchase price allocation performed for accounting purposes with respect to the acquisition attributes 20% of the purchase price to tangible property and identified Intangibles, including patents, and 80% to goodwill.

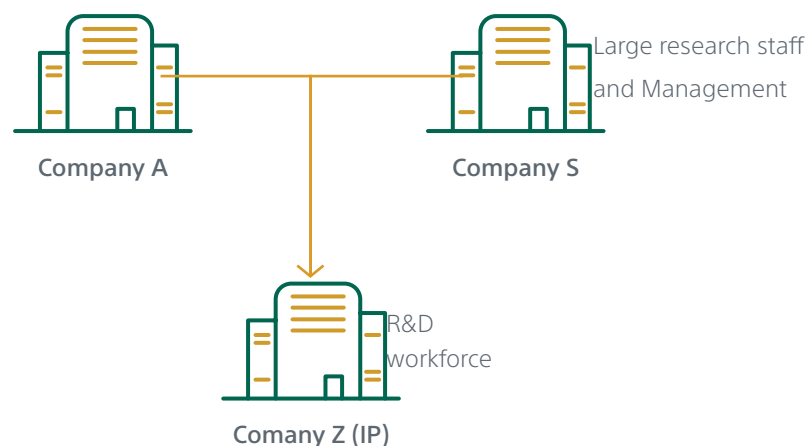

Figure 18 - Example of Intangibles (acquired by Independent Person)

- Immediately following the acquisition, Company A causes Company Z to transfer all of its rights in developed and partially developed technologies, including patents, trade secrets and technical know-how to Company S, a subsidiary of Company A.
- Company S simultaneously enters into a contract research agreement with Company Z, pursuant to which the Company Z workforce will continue to work exclusively on the development of the transferred technologies and on the development of new technologies on behalf of Company S

- The agreement provides that Company Z will be compensated for its research services by payments equal to its cost plus a mark-up, and that all rights to Intangibles developed or enhanced under the research agreement will belong to Company S.
- As a result, Company S will fund all future research and will assume the financial risk that some or all of the future research will not lead to the development of commercially viable products. Company S has a large research staff, including management personnel responsible for technologies of the type acquired from Company Z

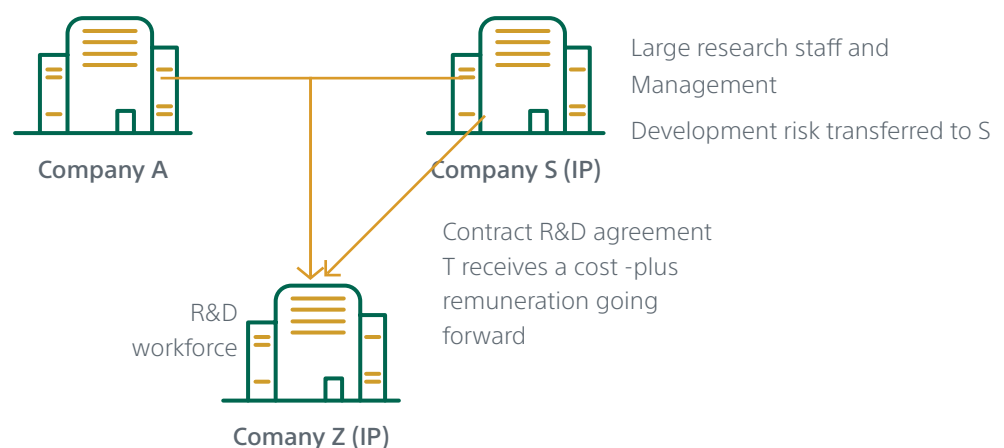

Figure 19 - Example of Intangibles transfer and remuneration going forward

- Following the Transactions in question, Company S' research and management personnel assume full management responsibility for the direction and control of the work of the Company Z research staff.
- Company S approves new projects, develops and plans budgets and in other respects controls the ongoing research work carried on at Company Z.
- All Company Z research personnel will continue to be employees of Company Z and will be devoted exclusively to providing services under the research agreement with The Company S
- In conducting a Transfer Pricing analysis on the Arm's Length Price to be paid by Company S for Intangibles transferred by Company Z, and of the price to be paid for ongoing R&D services to be provided by Company Z, it is important to identify the specific Intangibles transferred to Company S and those retained by Company Z. The definitions and valuations of Intangibles contained in the purchase price allocation are not determinative for Transfer Pricing purposes.

- The SAR 100 million paid by Company A for the shares of Company Z represents an Arm's Length Price for shares of the Person and provides useful information regarding the value of the business of Company Z
- The full value of that business should be reflected either in the value of the tangible and Intangible assets transferred to Company S or in the value of the tangible and Intangible assets and workforce retained by Company Z
- Depending on the facts, a substantial portion of the value described in the purchase price allocation as goodwill of Company Z may have been transferred to Company S together with the other Company Z Intangibles.
- Depending on the facts, some portion of the value described in the purchase price allocation as goodwill may also have been retained by Company Z
- Under Arm's Length Transfer Pricing Principles, Company Z should be entitled to compensation for such value, either as part of the price paid by Company S for the transferred rights to technology Intangibles, or through the compensation Company Z is paid in years following the Transaction for the R&D services of its workforce.
- It should generally be assumed that value does not disappear, nor is it destroyed, as part of an internal business restructuring. If the transfer of Intangibles to Company S had been separated in time from the acquisition, a separate inquiry would be required regarding any intervening appreciation or depreciation in the value of the transferred Intangibles.

Appendix 15 - General example in relation to specific guidance on Business Restructuring – Risk

The following general example gives specific guidance on Business Restructuring - Risk. Note that the example is purely for indicative purposes.

Potential transfer of credit risk?

Suppose that before a Business Restructuring, a distributor contractually assumes bad debt risks, which are reflected in the balance sheet at year end.

However, the analysis described above establishes that before the Business Restructuring, decisions about the extension of credit terms to customers and debt recovery were taken by a Related Person and not by the distributor, and the Related Persons reimbursed the costs of irrecoverable debts. In other words, the Related Person does take on control of management of the bad debt risks.

It is also determined that the Related Person is the only entity that controlled the risk and had the financial capacity to assume the bad debt risk, leading to the conclusion that, before the Business Restructuring, the risk was not assumed by the distributor.

In such a case there is no bad debt risk for the distributor to transfer as part of the Business Restructuring.

Reduction of inventory risk material?

Where a distributor is converted into a distributor exposed to less risk, resulting from the reduction or elimination of risks relating to inventory in the restructured Person (i.e. the Principal in the group will going forward control the management of the inventory risk), it is relevant to determine such reduction or elimination of risk is economically significant. The tax administration may want to analyze:

- The role of inventory in the business model (for example, speed to market, comprehensive range);
- The nature of the inventory (for example, spare parts, fresh flowers);
- The level of investment in inventory;

- The factors giving rise to inventory write-downs or obsolescence (for example, perishability, pricing pressures, speed of technical improvements, market conditions);
- The history of write-down and stock obsolescence, and whether any commercial changes affect the reliability of historic performance as an indicator of current risk;
- The cost of insuring against damage or loss of inventory; and
- The history of damage or loss (if uninsured).

Appendix 16 - General example in relation to specific guidance on Business Restructuring – Distributor

The following general example gives specific guidance on Business Restructuring - Distributor. Note that the example is purely for indicative purposes.

- Assume distributor is operating under a long term contractual arrangement for a given type of Transaction.
- Assume that, based on its rights under the long term contract with respect to these Transactions, it has the option realistically available to it to accept or refuse being converted into a distributor exposed to less risk operating for a Foreign Related Person, and that an Arm's Length remuneration for such a low risk distribution activity is estimated to be a stable profit of +2% per year while the excess profit potential associated with the risks would now be attributed to the Foreign Related Person.
- Assume for the purpose of this example that the restructuring leads to the renegotiation of the existing contractual arrangements, but it does not entail the transfer of assets other than its rights under the long-term contract.
- From the perspective of the distributor, the question arises as to whether the new arrangement (taking into account both the remuneration for the post-restructuring Transactions and any compensation for the restructuring itself) is expected to make it as well off as its realistic – albeit riskier – alternatives. If not, this would imply that the post-restructuring arrangement is not priced at Arm's Length and that additional compensation would be needed to appropriately remunerate the distributor for the restructuring, or that an assessment of the commercial rationality of the Transaction may be necessary.
- For Transfer Pricing purposes, it is important to determine whether risks contractually transferred as part of the Business Restructuring, are assumed by the Foreign Related Person.
- At Arm's Length, the response is likely to depend on the rights and other assets of the Persons, on the profit potential of the distributor and of its Related Person in relation to both business models (distributor exposed to fewer risks) as well as the expected duration of the new arrangement.
- In particular, in evaluating profit potential, it is necessary to evaluate whether historic profits (determined in accordance with the Arm's Length Principle) are an indicator of future profit potential, or whether there have been changes in the business environment

around the time of the restructuring that mean that past performance is not an indicator of profit potential. For example, competing products could have the effect of eroding profitability, and new technology or consumer preferences could render the products less attractive.

- The consideration of these factors from perspective of the distributor can be illustrated with the following example.

	Scenario 1	Scenario 2	Scenario 3
Distributor Historical Profitability data (Last year)	Year 1 -2% Year 2 4% Year 3 2% Year 4 0% Year 5 6%	Year 1 5% Year 2 10% Year 3 5% Year 4 5% Year 5 5%	Year 1 -2% Year 2 4% Year 3 2% Year 4 0% Year 5 6%
Distributor Projected Profitability (over remaining term or agreement)	(-2)% to 6% with significant uncerainties within this range	5% to 10% with significant uncerainties within this range	0% to 4% with significant uncerainties within this range
Distributor Distributor exposed to fewer risks	2% per year	2% per year	2% per year

Considerations in view of the 3 scenarios:

1. In scenario number 1, the distributor is surrendering a profit potential with significant uncertainties for a relatively low but stable rate of profitability. Whether an Independent Person would be willing to do so would depend on its anticipated return under both scenarios, on its level of risk tolerance, on its options realistically available and on possible compensation for the restructuring itself.
2. In case scenario number 2, it is unlikely that Independent Persons in the distributor's situation would agree to relocate the risks and associated profit potential for no additional compensation if they had the option to do otherwise.
3. Scenario number 3 illustrates the fact that the analysis should take account of the profit potential going forward and that, where there is a significant change in the commercial or economic environment, relying on historical data alone will not be sufficient.

As a general note when considering a somewhat lower profit of the distributor exposed to fewer risks. as a result of a reduction of risks it controls (and thus is exposed to) can be considered appropriate if all is properly substantiated.

With respect to any potential compensation (i.e. indemnification or termination payment) it is noted that in principle the legal arrangement should be taken as a starting point to determine whether an indemnification or termination payment is required. If the termination/indemnification clauses in the legal arrangement are not considered at Arm's Length the appropriate termination/indemnification should be further determined based on the specific facts and circumstances.

